

STRwrench

atlascopco.com



Atlas Copco

STRwrench

Tightening in manufacturing has never been more critical to production quality and economics. With the never-ending need to connect parts along an assembly line, one single tightening error can cause the

production line to go down. This requires a tightening tool that is highly accurate, reliable and provides operator-friendly ergonomics. Let us present our electronic wrench family; the STRwrench

Connectivity

The STRwrench Compact and Advanced models offer built-in Wi-Fi and BT communication connectivity features. In addition, the STRwrench is designed to enable universal access and settings through web browsers into the Smart Integrated Assembly.

Flexibility

By digitizing the transducers, STRwrench unlocks the hot-swap feature. This enables the operator to change the wrench capacity whilst keeping the wrench on, connected, and performing. The design and choice of materials make it possible to swap the smartHEAD without affecting the overall operability and durability. Features that optimize the number of the tools and save time. In addition, the STRwrench is now able to measure with high accuracy starting at 5% of the nominal torque.

Quality

In order to improve the quality of the final assembly, the STRwrench, thanks to its new colored screen, is easier to use, reducing the possibility of mistakes for the operator. The product is now tested against drops and falling objects in order to reach the highest robustness level in the market, guaranteeing a long durability and minimizing product failures.

Reliability

The STRwrench is easy to use and provides feedback to the operator, reducing the occurrence of errors. Vibration, LED strings, and sounds, guide the user to a perfect tightening operation. In combination with the non-length handling dependance, the STRwrench is completely operator independent. And thanks to the 30% extended battery duration, the wrench is always powered, guaranteeing operational continuity.

Ergonomics

The STRwrench takes operator accessibility and maneuverability to a new level. The optimized compact dimensions and the 90° rotational smartHEAD enable the operator to easily access even the most difficult joints.



Production

Robustness

The STRwrench is the toughest wrench in the market delivering against the most challenging durability and robustness tests with honors. The new innovative locking system allows more than 50,000 swaps of the smartHEAD. The connection pins of the controller with the smartHEAD have also been re-designed, thereby guaranteeing the highest level of measurement reliability.



Feedback

The operator feedback has been improved. The colored screen provides clear messages to the operator, increasing the awareness during the tightening operations. In addition, the new dynamic LED solution combined with the handle vibration and buzzer, enables a quicker fastening operation that supports tough takt time production challenges.

Digitalization

The smartHEAD is now digitalized which means that the torque values are calculated directly by the transducers and sent to the STRwrench controller. This allows for only the smartHEADs to be calibrated making them always ready to measure and interoperable with any controller. The digitalization also enables an optimization of the tool base to cover several torque levels with just one controller and multiple smartHEADs covering any needed capacity.

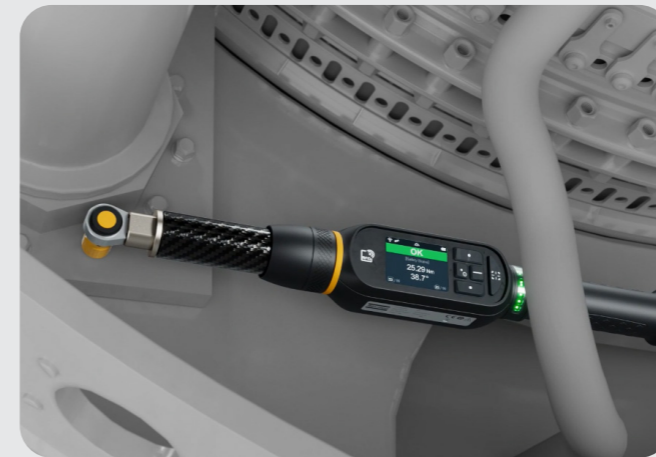

Operator friendly

The STRwrench is very easy to handle and is adapted to the working environment. The 90° rotation of the smartHEAD guarantees that the operator always has visibility of the screen, minimizing the risk for human errors. The length of the handle has been increased thereby improving operator safety.

Fast back-up

Since the smartHEADs are digital and ready to measure, this facilitates a fast and quick back-up in the case the wrench becomes overloaded. It is no longer required to remove a faulty wrench from the assembly line causing a production stop. Instead, only the smartHEAD needs to be changed which can be performed while the wrench is powered on. All is completed within a matter of seconds and all data and events are saved in the controller.

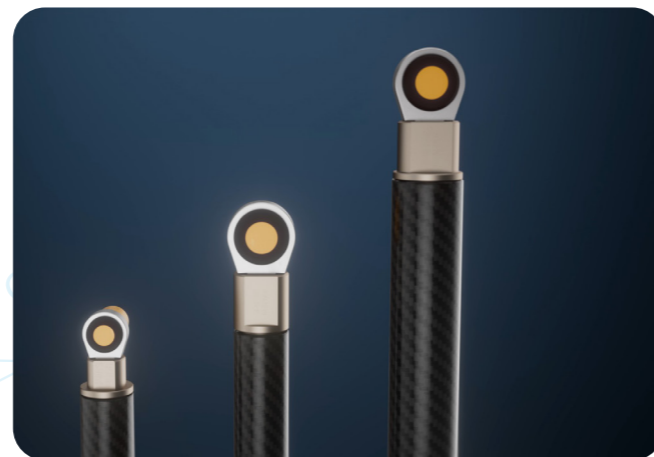

System integration

The wrench is always powered on and connected, even when the smartHEAD is swapped thereby guaranteeing traceability and data analysis. The STRwrench can be perfectly integrated in any system thanks to the native Open Protocol communication. The 2D barcode reader, the TAG management and the easy connection to an error proofing system unlock the most extensive poka-yoke system available. By tracing all operations, the risk is reduced for mistakes and faulty tightening's.

Quality

The STRwrench covers all the Quality Assurance applications providing the freedom of choice for customers to select the hardware they prefer to adapt to multiple brownfield and greenfield challenges. Despite the different hardware models – STRwrench Compact or STRwrench Advanced – they offer the same high product quality to perform an objective residual torque check.



Operator friendly

Setting up a quality inspection has never been easier. This can be performed by using the large touchscreen on the Advanced Controller - which can be performed using safety gloves - via web GUI simply typing the IP address of the wrench on a generic web browser, or remotely utilizing our QA Supervisor application. Easy comprehensible feedback and an intuitive user interface guide the operator to using the wrench in the best and most effective way, thanks also to the possibility to add pictures and notes.



Robustness

Product durability is also a priority for the quality department. All our hardware is tested and shares the same design. In addition, the Advanced Controller has positively passed the durability test - drop test and falling object tests - guarantying a long product lifespan.



System integration

The STRwrench is a native QA Supervisor product. Routes, inspections, and statistical analysis are conducted automatically by simply connecting the wrench to the Atlas Copco QA Platform 4.0. The STRwrench is also, thanks to its embedded connectivity features, included in the Quality Integrated Ecosystem and thereby easy to perfectly integrate in any third-party QA system, answering to the most challenging needs of traceability and data reporting.

Hot swap

Optimization of the tool base can be done thanks to the STRwrench hot swap feature. Routes and inspections are administrated by the controller that suggests to the operator the correct smartHEAD capacity to be swapped. The result is less hardware along the assembly line with only one controller used for multiple applications and improved ROI.

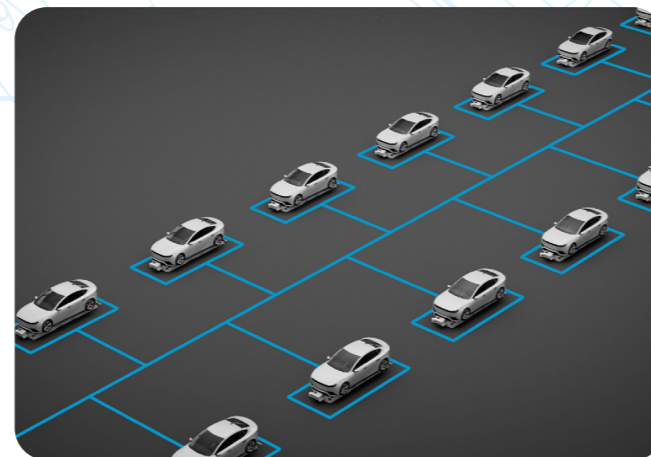

Patented algorithm

The STRwrench has a patented algorithm to calculate the residual torque. The wrench automatically detects and saves the breakaway, the residual torque, and the peak left to the joint. This way the joint check operation is completely operator-independent providing objective data and a reliable quality control. Other commons quality strategies are available by default to guarantee maximum flexibility to match individual customer specifications.



R&D and Prototyping

The STRwrench can also be used for joint analysis. Thanks to the high level of accuracy, it is possible to in detail analyze the joint, identifying the right torque and specifications during the prototyping phase. With the Live Trace feature, it is also possible to analyze the behavior of the joint during the tightening in real-time.

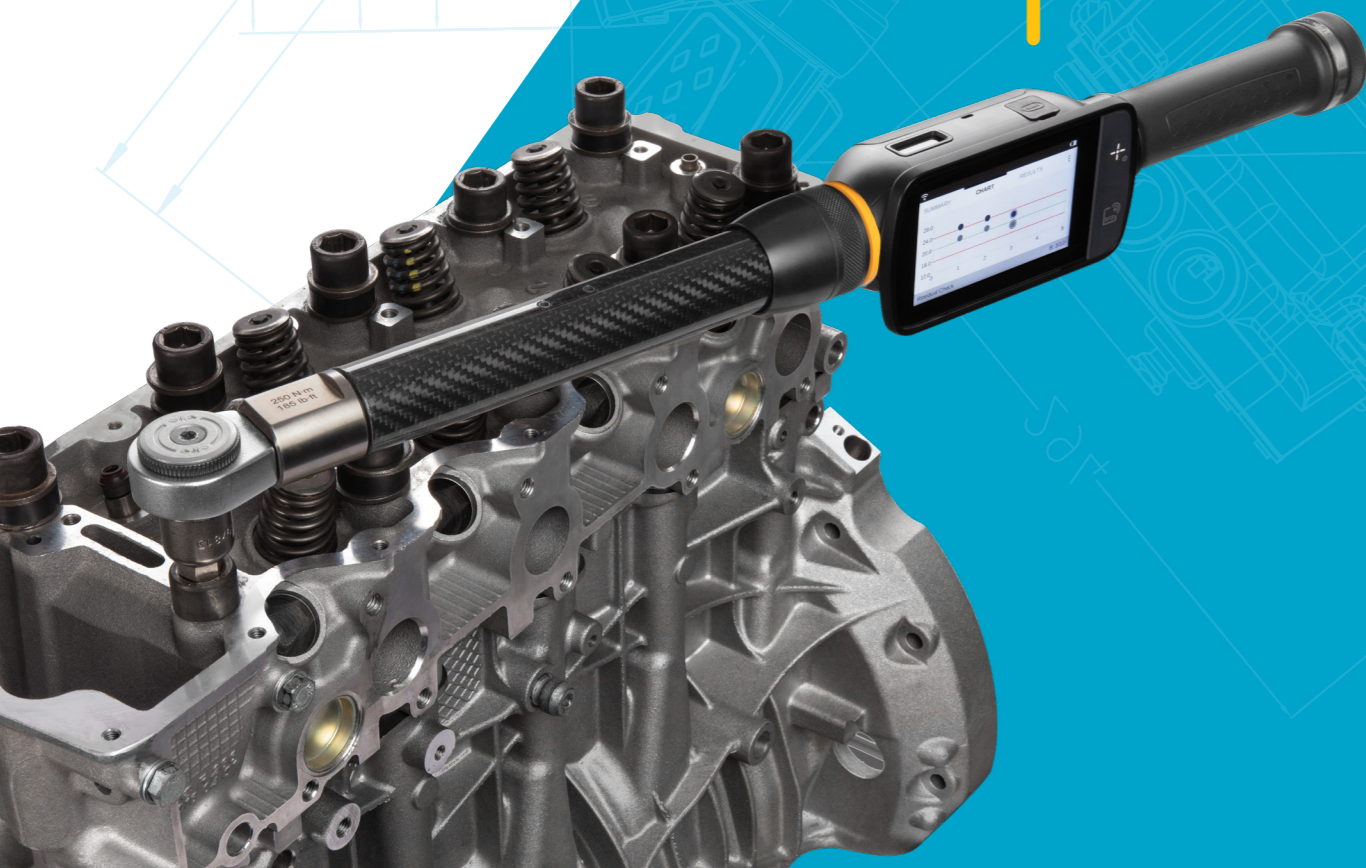

Integrated Ecosystem

The STRwrench is a prominent part in the Atlas Copco Quality Integrated Ecosystem. The joint check analysis performed with the wrench is directly reported to the QA Supervisor, unlocking real-time results, and feeding together with production data and machine capabilities data the Joint Report.

The STRwrench is fully integrated with Atlas Copco's Smart Integrated Assembly ecosystem. It can easily be connected to any Power Focus tool, our ToolsNet 8 solution for data traceability and to the Atlas Copco Error Proofing solution portfolio.



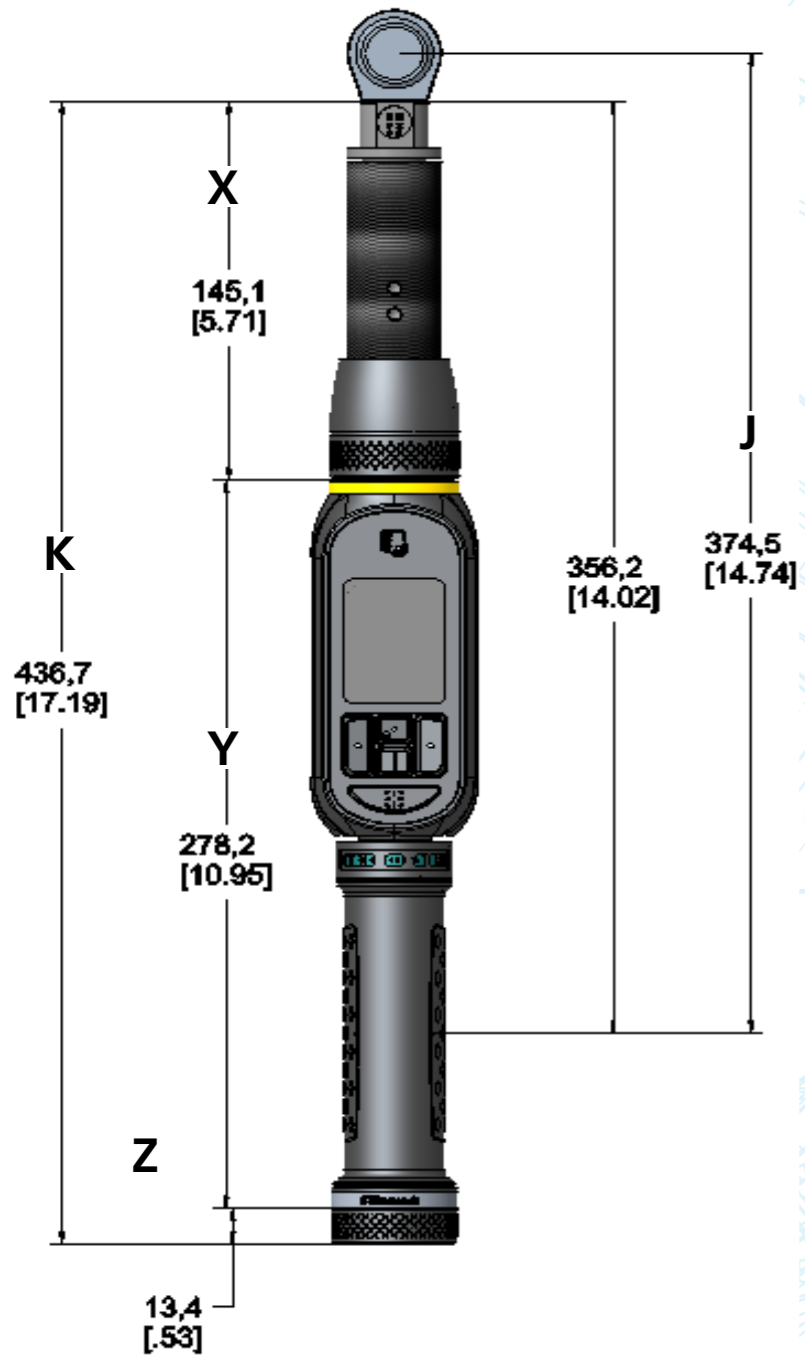

Description	Ordering Number
STRwrench	
Controller Compact	8059 0924 00
Controller Advanced	8059 0924 01
smartHEAD 80 Nm	8059 0924 42
smartHEAD 250 Nm Short	8059 0924 43
smartHEAD 250 Nm Long	8059 0924 44
smartHEAD 400 Nm	8059 0924 45
STRwrench Battery	8059 0924 06
STRwrench Charger	8059 0924 10
Compact rubber protection	8059 0924 25
Advanced rubber protection	8059 0924 26
80 Nm smartHEAD rubber protection	8059 0924 28
250 Nm Short smartHEAD rubber protection	8059 0924 29

Description	Ordering Number
STRwrench	
250 Nm Long smartHEAD rubber protection	8059 0924 30
400 Nm smartHEAD rubber protection	8059 0924 31
Integrated Controller Production Electronic delivery	8059 0983 00
Integrated Controller Production Physical delivery	8059 0983 01
Integrated Controller QA Electronic delivery	8059 0983 02
Integrated Controller QA Physical delivery	8059 0983 03
Integrated Controller Prod AddOn Electronic delivery	8059 0983 10
Integrated Controller Prod AddOn Physical delivery	8059 0983 11
Integrated Controller QA AddOn Electronic delivery	8059 0983 12
Integrated Controller QA AddOn Physical delivery	8059 0983 13
Advanced Joint check Elctronic delivery	8059 0983 14
Advanced Joint check Physical delivery	8059 0983 15

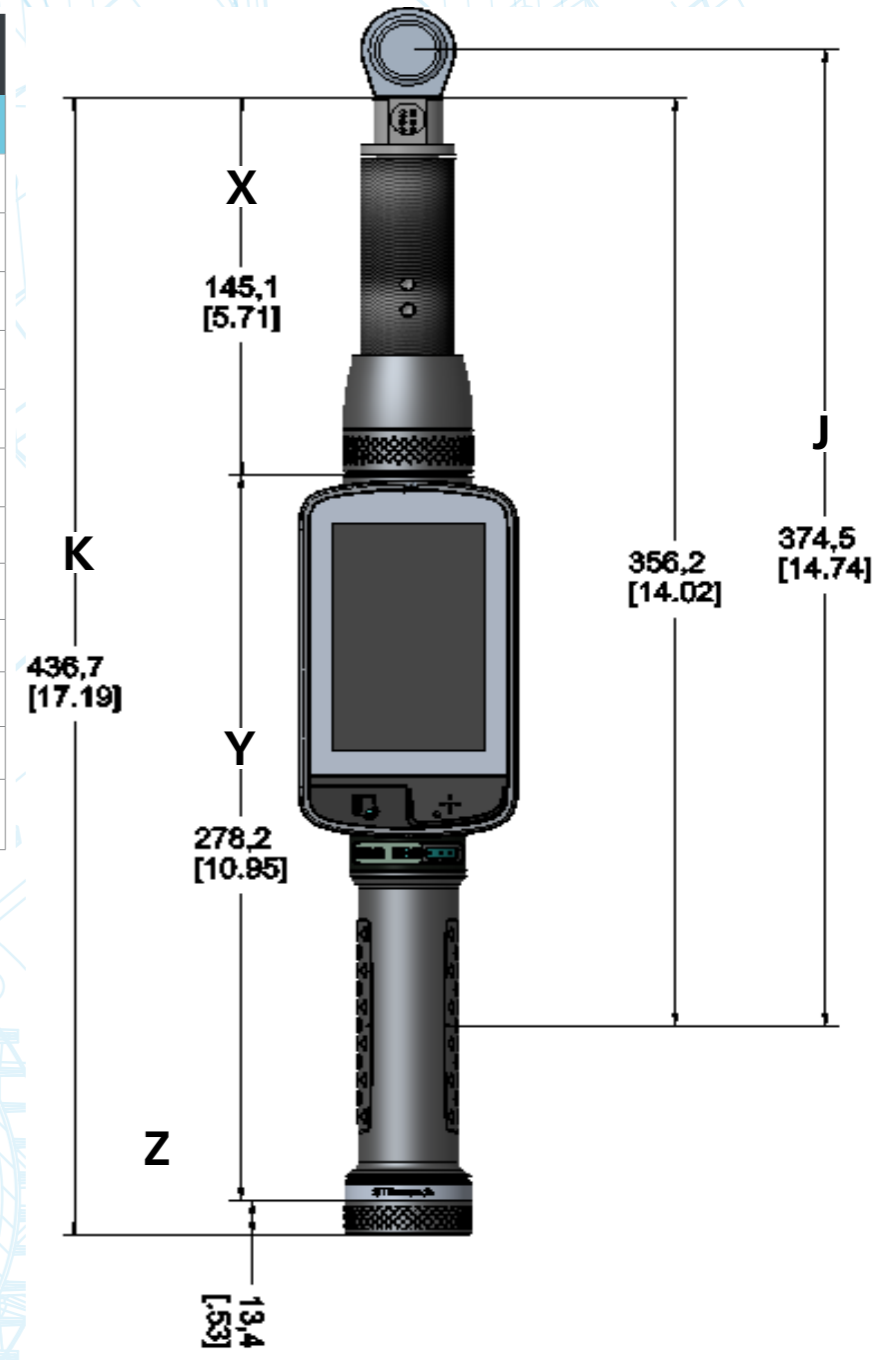

STRwrench Compact												
Model	X		Y		Z		J		K		Weight	
	mm	in	mm	in	mm	in	mm	in	mm	in	Kg	lb
smartHEAD 80Nm	145	5,71	278	10,94	13,4	0,53	374	14,72	437	17,20	1.45	3.19
250Nm short	262	10,31	278	10,94	13,4	0,53	499	19,65	554	21,81	2.05	4.53
250Nm long	462	18,19	278	10,94	13,4	0,53	699	27,52	754	29,69	2.16	4.76
400Nm	583	22,96	278	10,94	13,4	0,53	825	32,48	874	34,41	2.80	6.17

STRwrench Advanced												
Model	X		Y		Z		J		K		Weight	
	mm	in	mm	in	mm	in	mm	in	mm	in	Kg	lb
smartHEAD 80Nm	145	5,71	278	10,94	13,4	0,53	374	14,72	437	17,20	1.60	3.53
250Nm short	262	10,31	278	10,94	13,4	0,53	499	19,65	554	21,81	2.20	4.86
250Nm long	462	18,19	278	10,94	13,4	0,53	699	27,52	754	29,69	2.31	5.09
400Nm	583	22,95	278	10,94	13,4	0,53	825	32,48	874	34,41	2.95	6.50



Atlas Copco Tools Central Europe GmbH

Langemarckstraße 35, 45141 Essen

tools.de@atlascopco.com

+49 (0) 201 2177 0

www.atlascopco.com

