

PART	Status	Rev./Iter
GFA-00T-70-18-13-N01P	In Work	0.0
Drawing	Status	Rev./Iter
GFA-00T-70-18-13-N01P		0.0

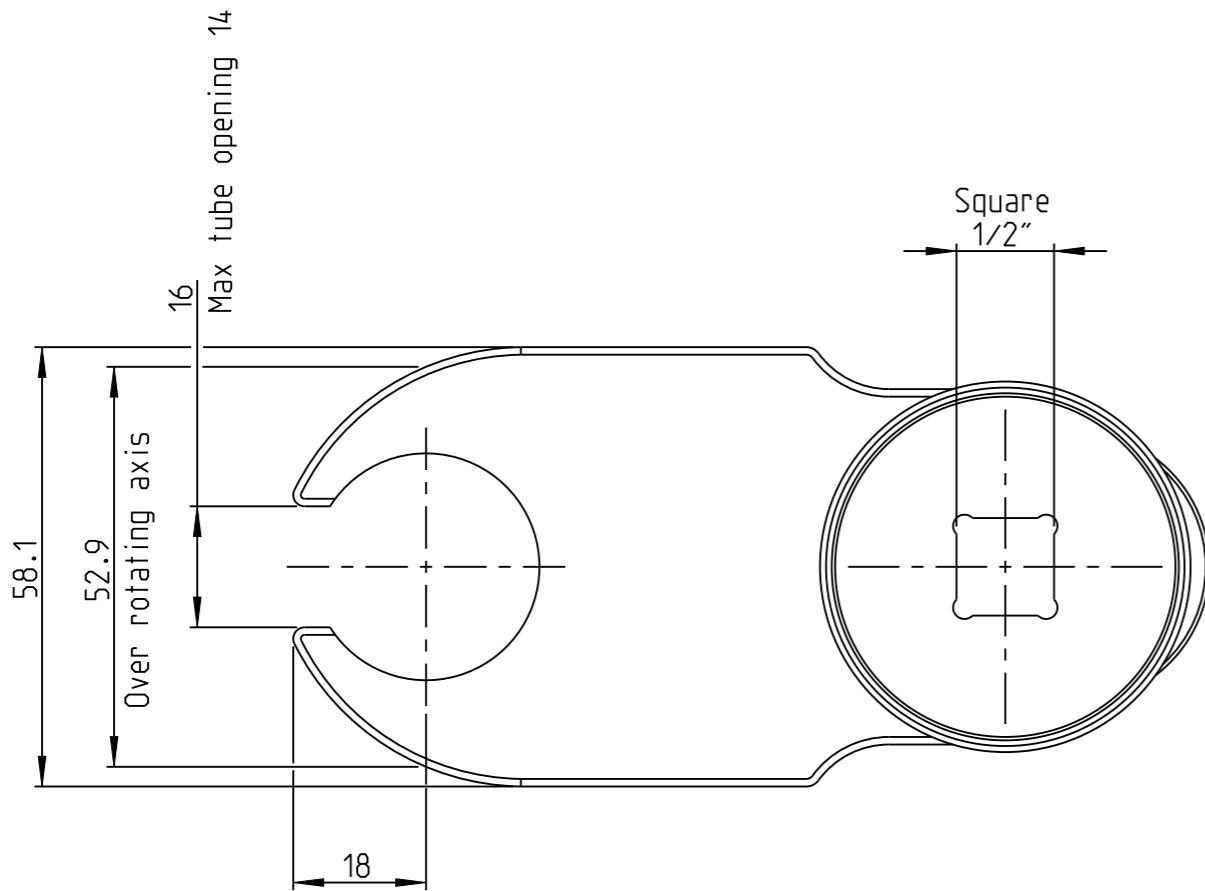
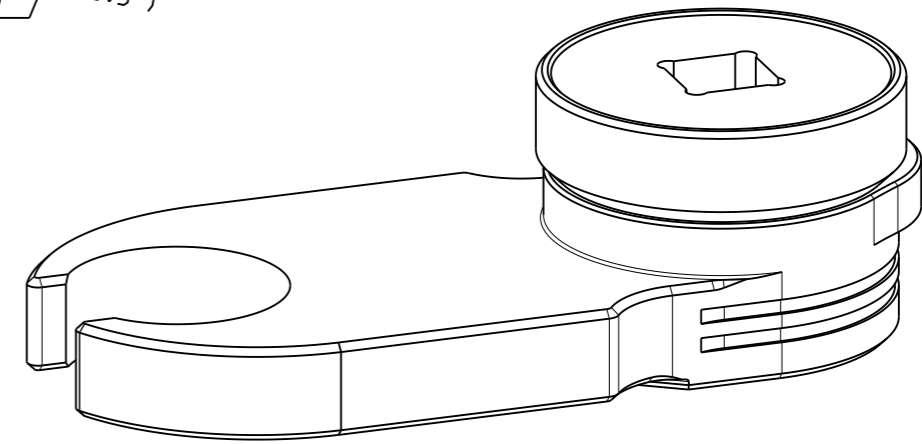
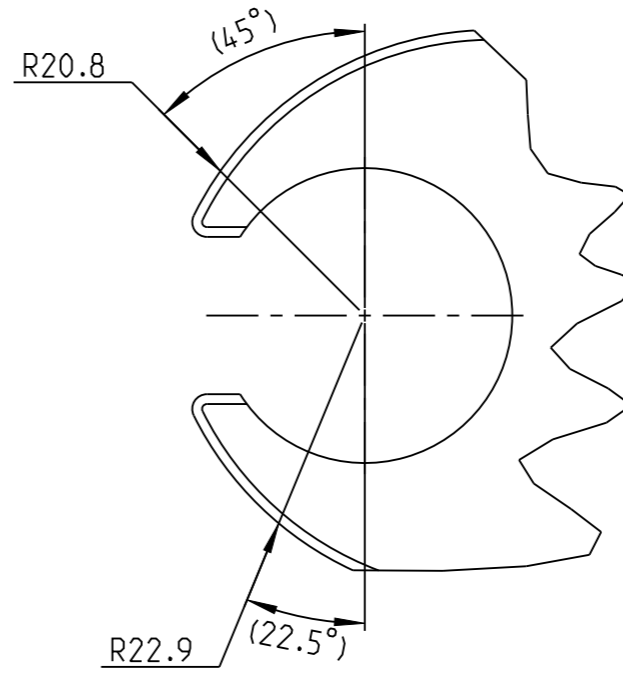
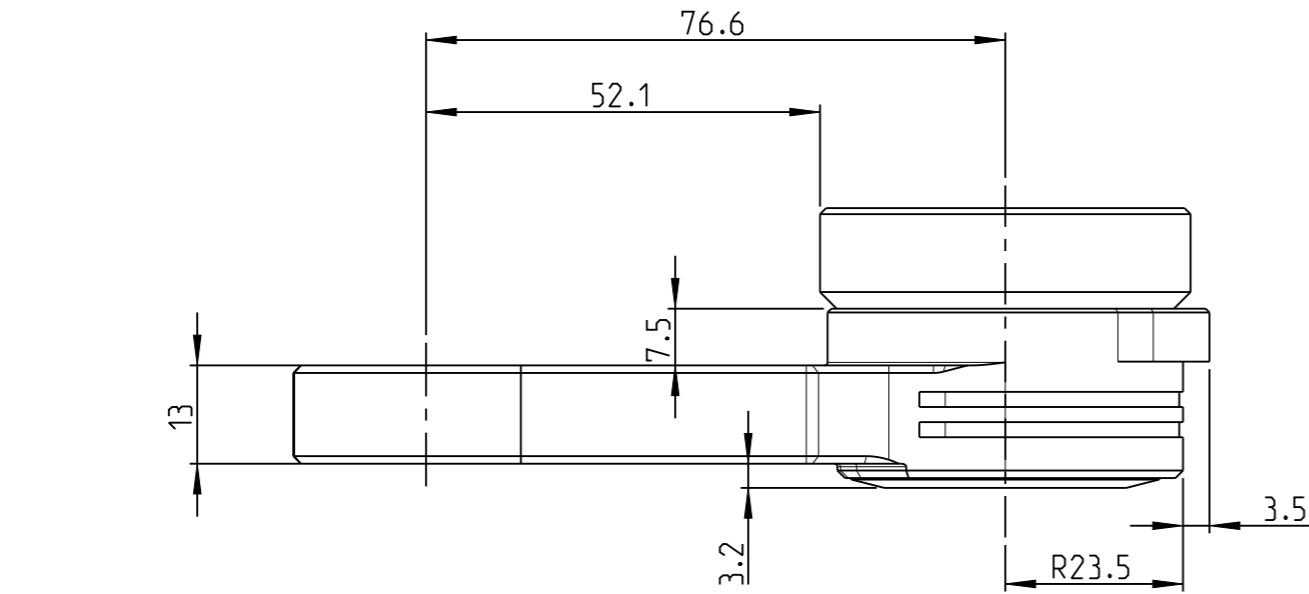

Input size	Square 1/2"
Gear stages	3
Input gear rotational direction	CCW
Theoretical efficiency	0.77
Gear ratio	1.00
Max output torque	51.00 Nm
Max input torque	66.30 Nm
Approximate weight	0.7 kg
Max hex output size A/F	17 mm

SALTUS	Name	GFA-00T-C-70-18-13-3
	Designation	3512180081

proprietary document. Not to be used in any way without our consent.

PART	Status	Rev./Iter
GFA-00T-70-18-13-N01P	In Work	0.0
Drawing	Status	Rev./Iter
GFA-00T-70-18-13-N01P		0.0

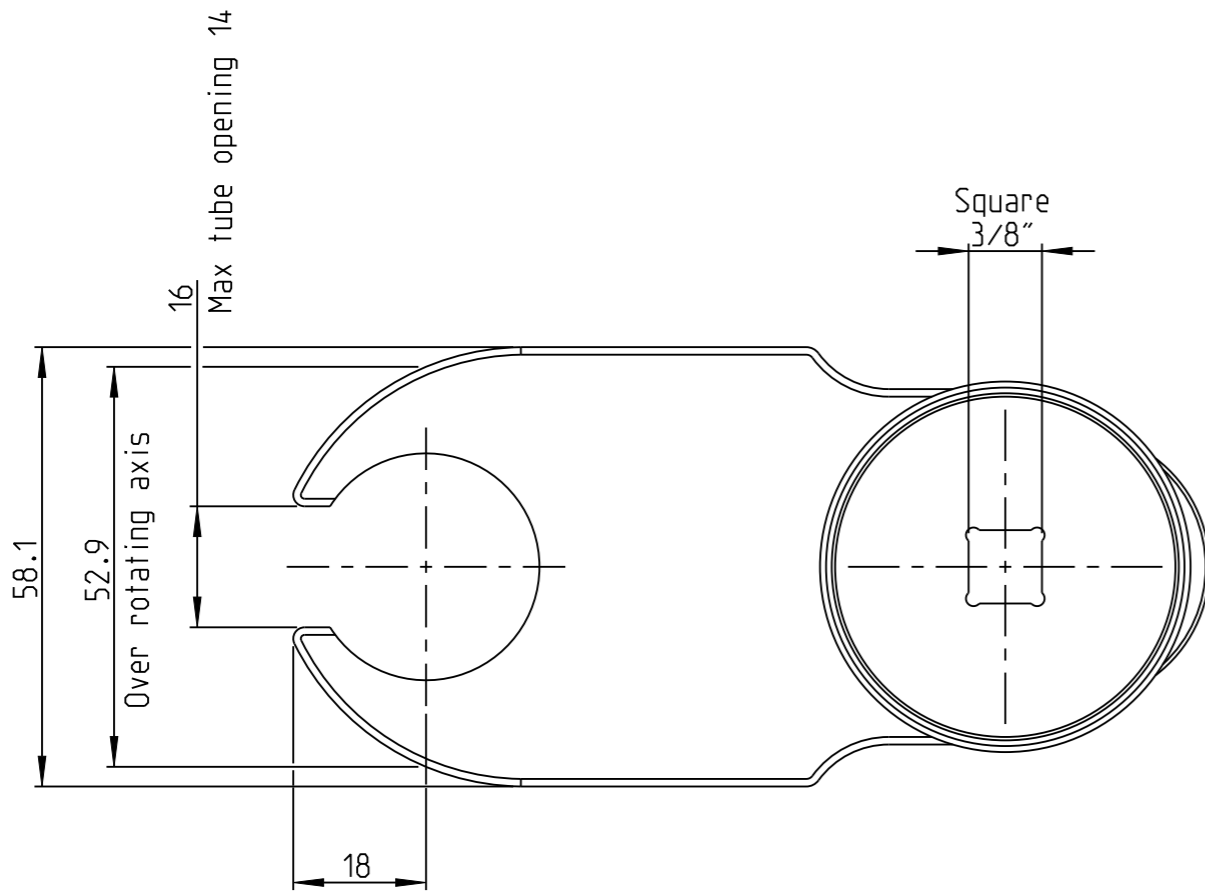
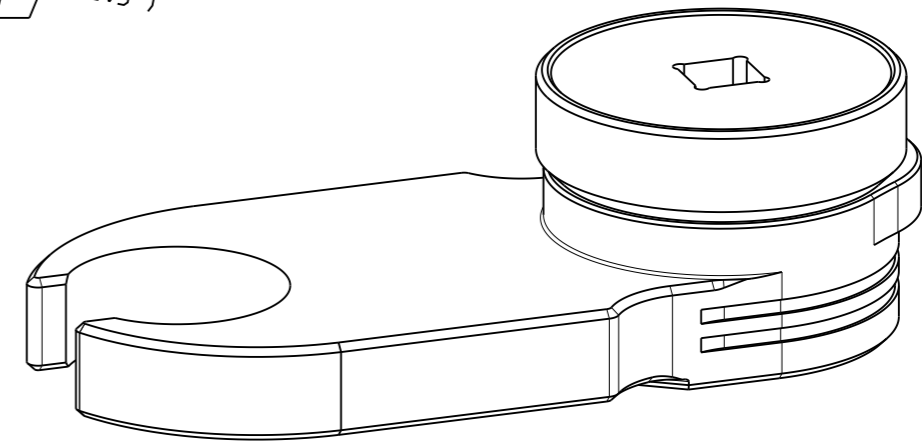
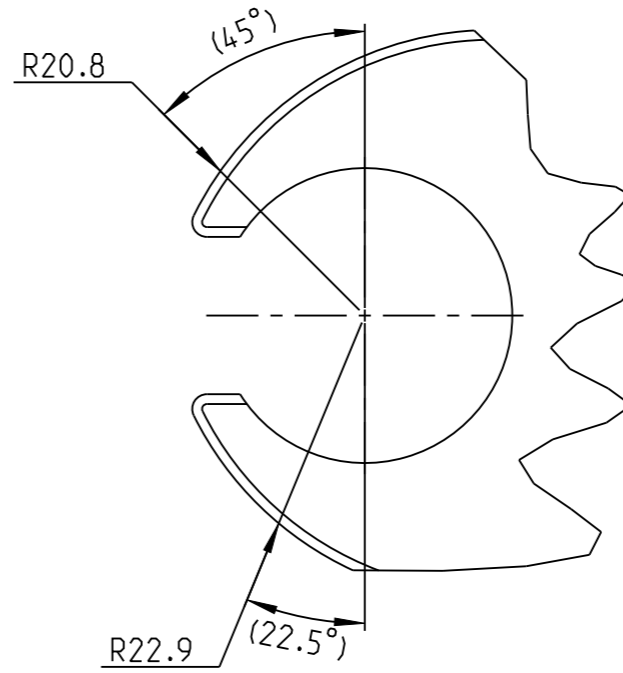
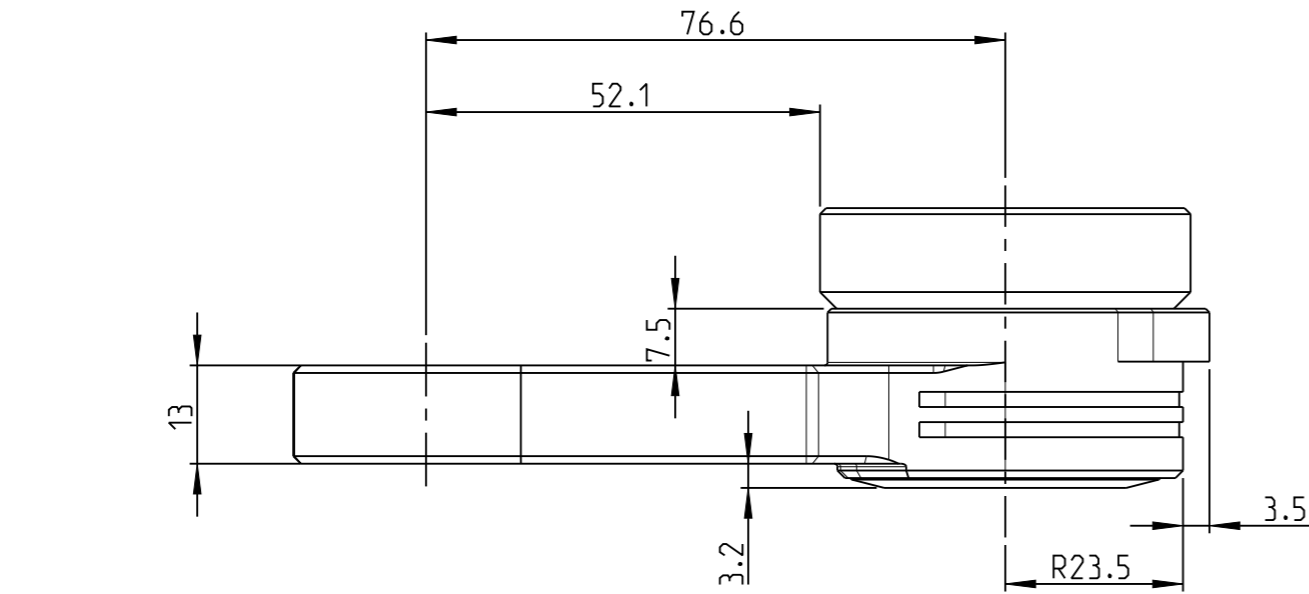

Input size	Square 3/8"
Gear stages	3
Input gear rotational direction	CCW
Theoretical efficiency	0.77
Gear ratio	1.00
Max output torque	51.00 Nm
Max input torque	66.30 Nm
Approximate weight	0.71 kg
Max hex output size A/F	17 mm

proprietary document. Not to be used in any way without our consent.

SALTUS

Name
GFA-00T-B-70-18-13-3
Designation
3512180082

PART	Status	Rev./Iter
GFA-00T-70-18-13-N01P	In Work	0.0
Drawing	Status	Rev./Iter
GFA-00T-70-18-13-N01P		0.0

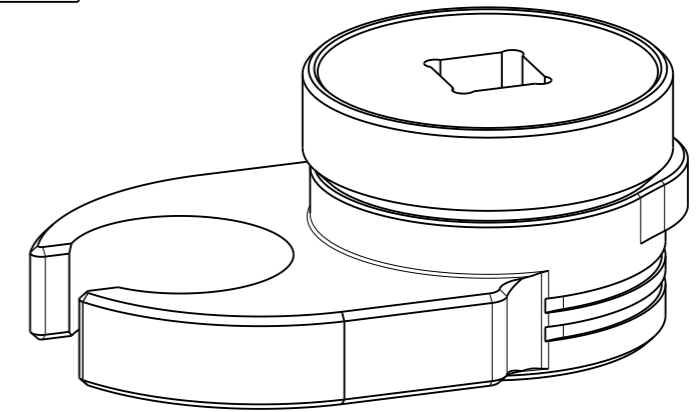
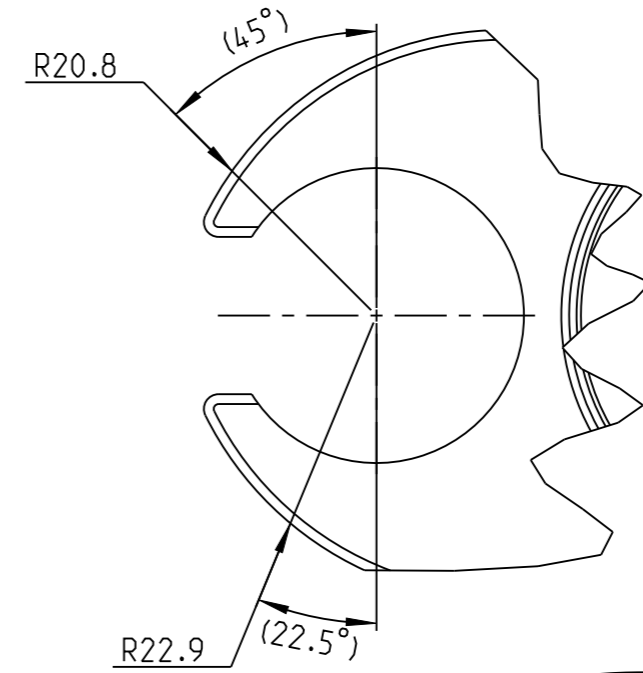
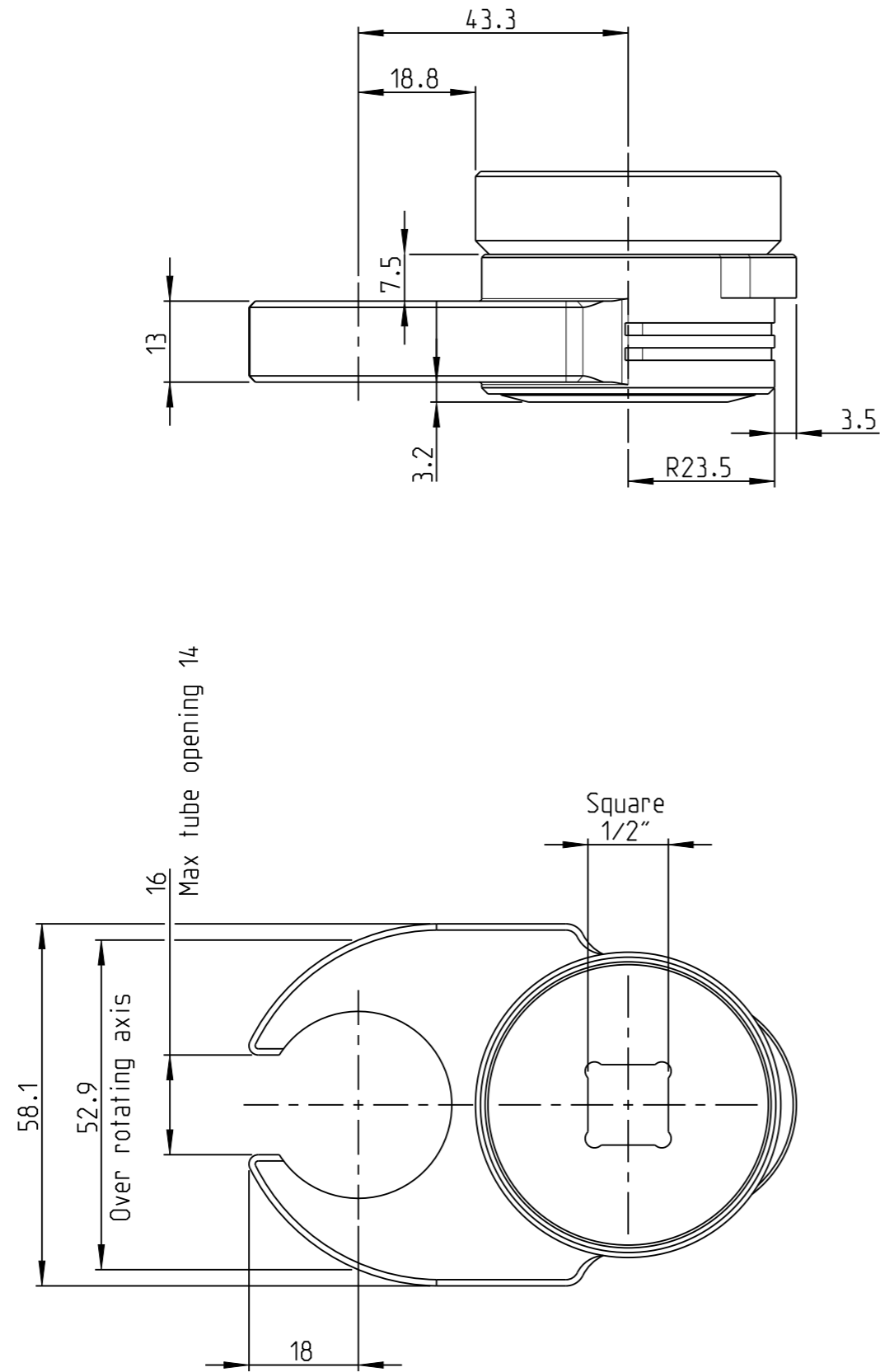

Input size	Square 1/2"
Gear stages	2
Input gear rotational direction	CW
Theoretical efficiency	0.82
Gear ratio	1.00
Max output torque	51.00 Nm
Max input torque	62.20 Nm
Approximate weight	0.54 kg
Max hex output size A/F	17 mm

proprietary document. Not to be used in any way without our consent.

SALTUS

Name	GFA-00T-C-70-18-13-2
Designation	3512180083

PART	Status	Rev./Iter
GFA-00T-70-18-13-N01P	In Work	0.0
Drawing	Status	Rev./Iter
GFA-00T-70-18-13-N01P		0.0

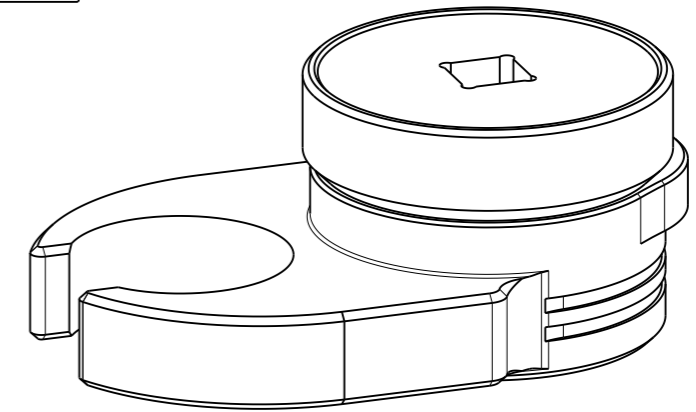
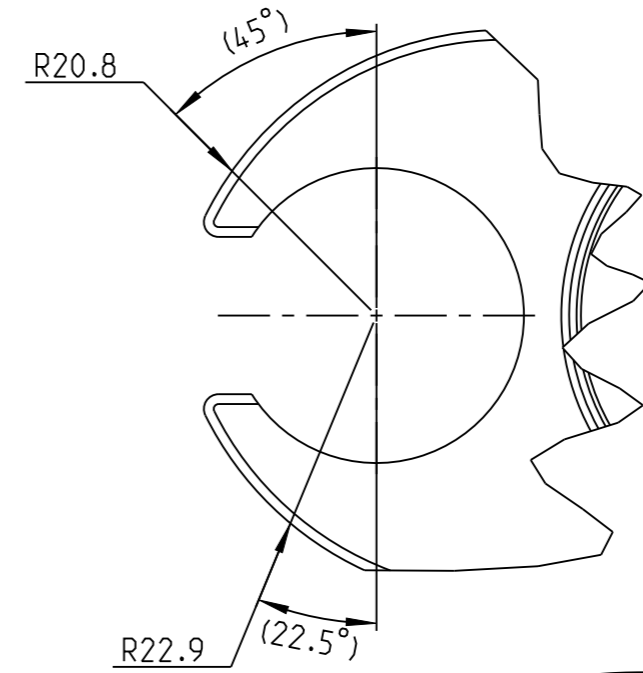
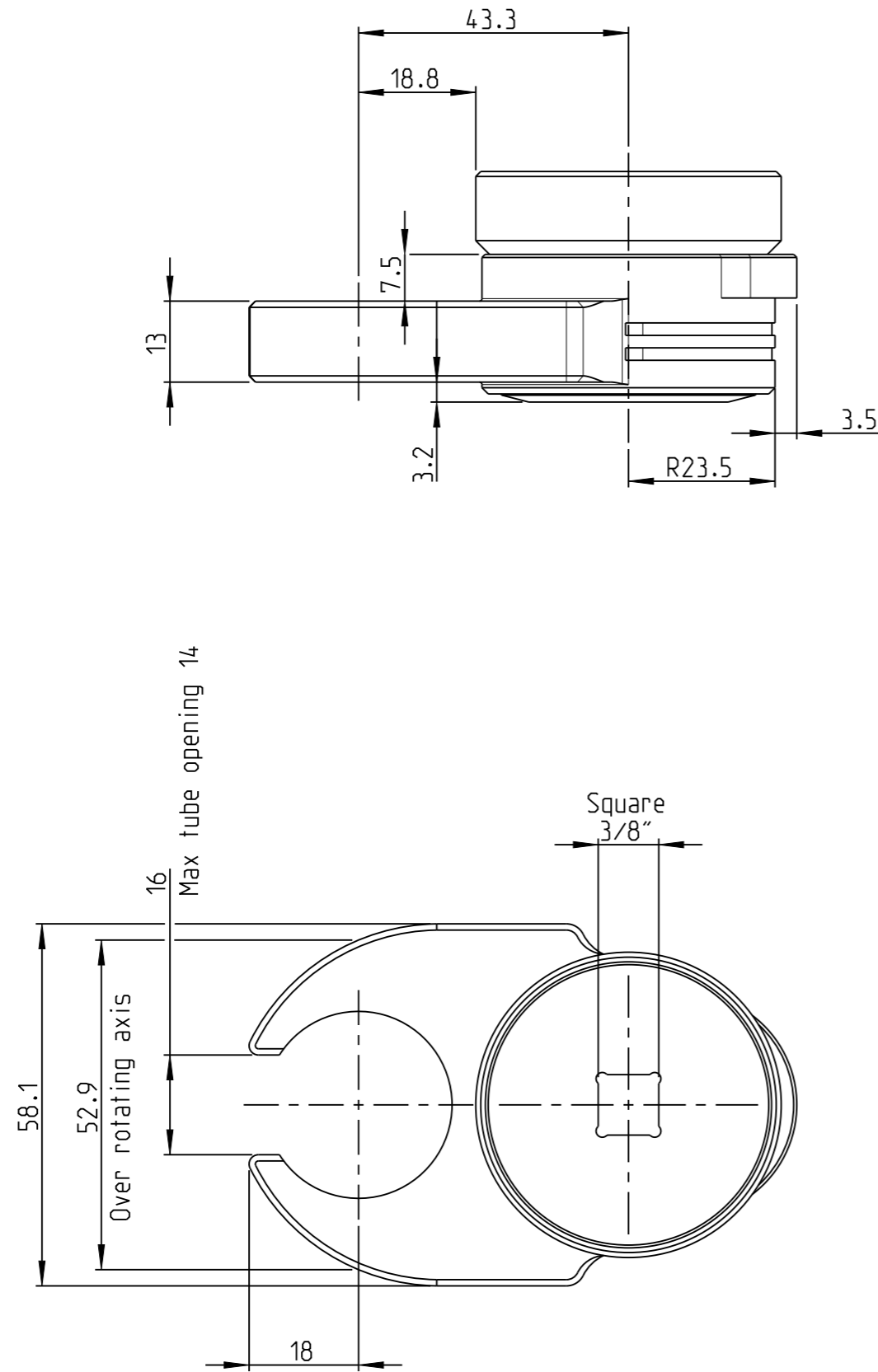

Input size	Square 3/8"
Gear stages	2
Input gear rotational direction	CW
Theoretical efficiency	0.82
Gear ratio	1.00
Max output torque	51.00 Nm
Max input torque	62.20 Nm
Approximate weight	0.55 kg
Max hex output size A/F	17 mm

SALTUS	Name	GFA-00T-B-70-18-13-2
	Designation	3512180084

proprietary document. Not to be used in any way without our consent.

PART	Status	Rev./Iter
GFA-00T-70-18-13-N01P	In Work	0.0
Drawing	Status	Rev./Iter
GFA-00T-70-18-13-N01P		0.0

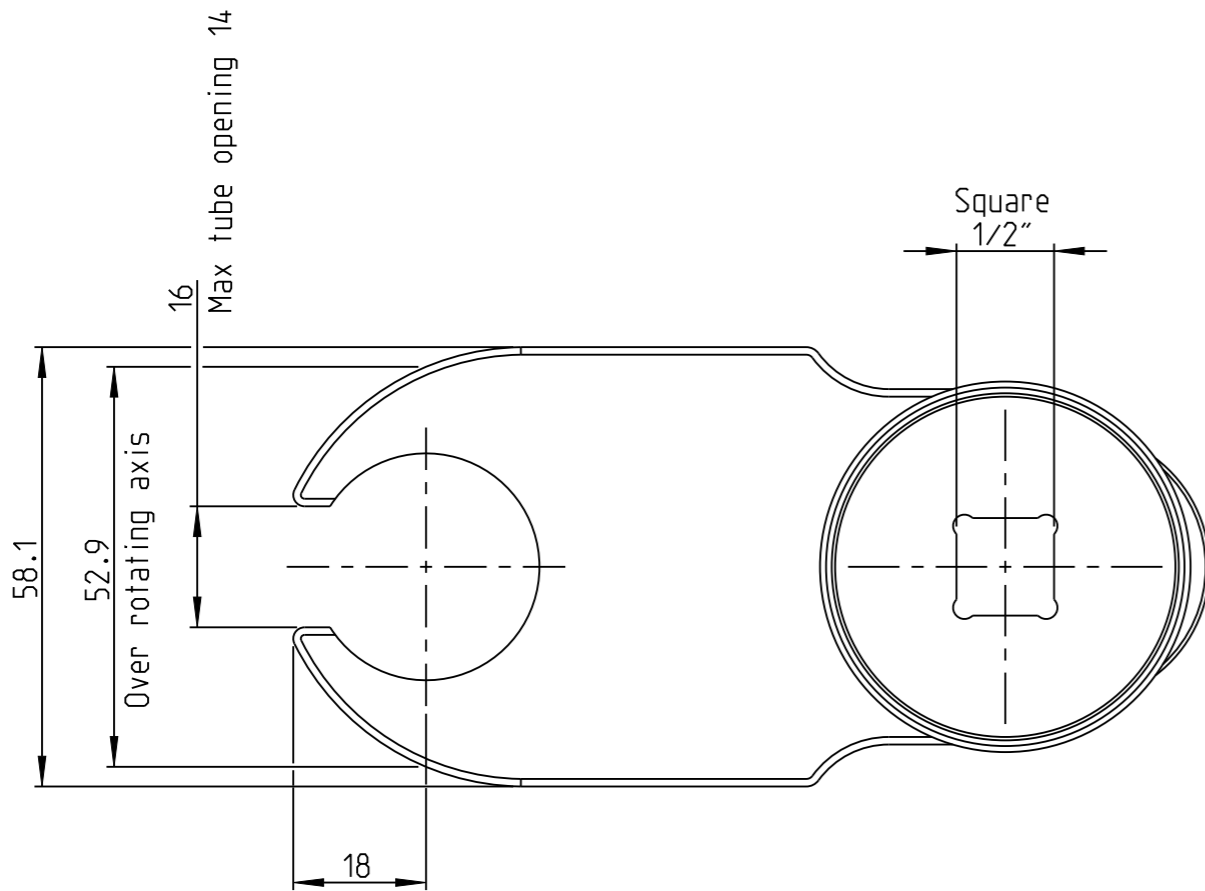
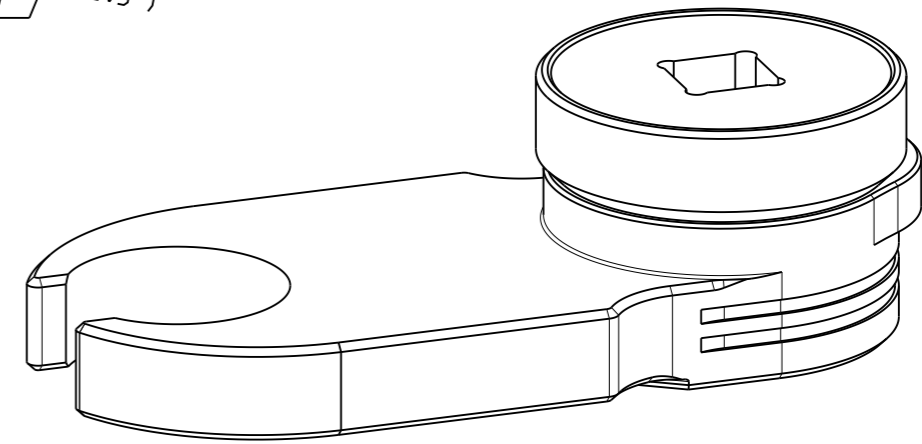
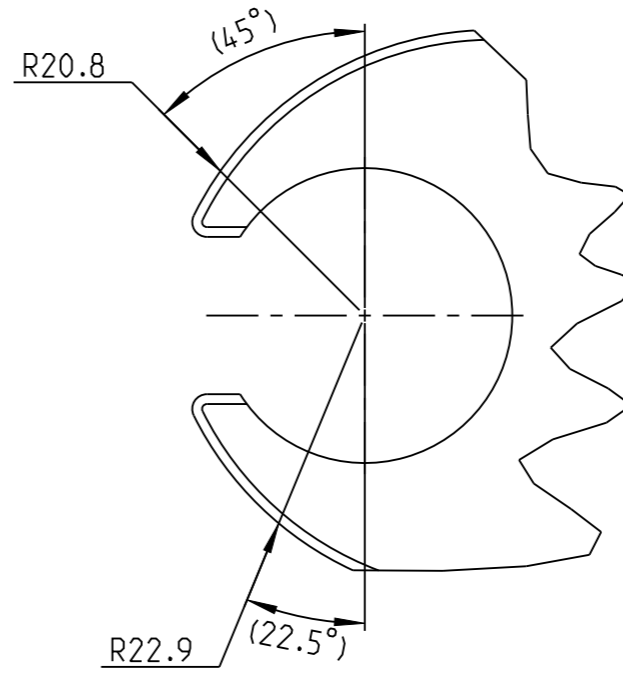
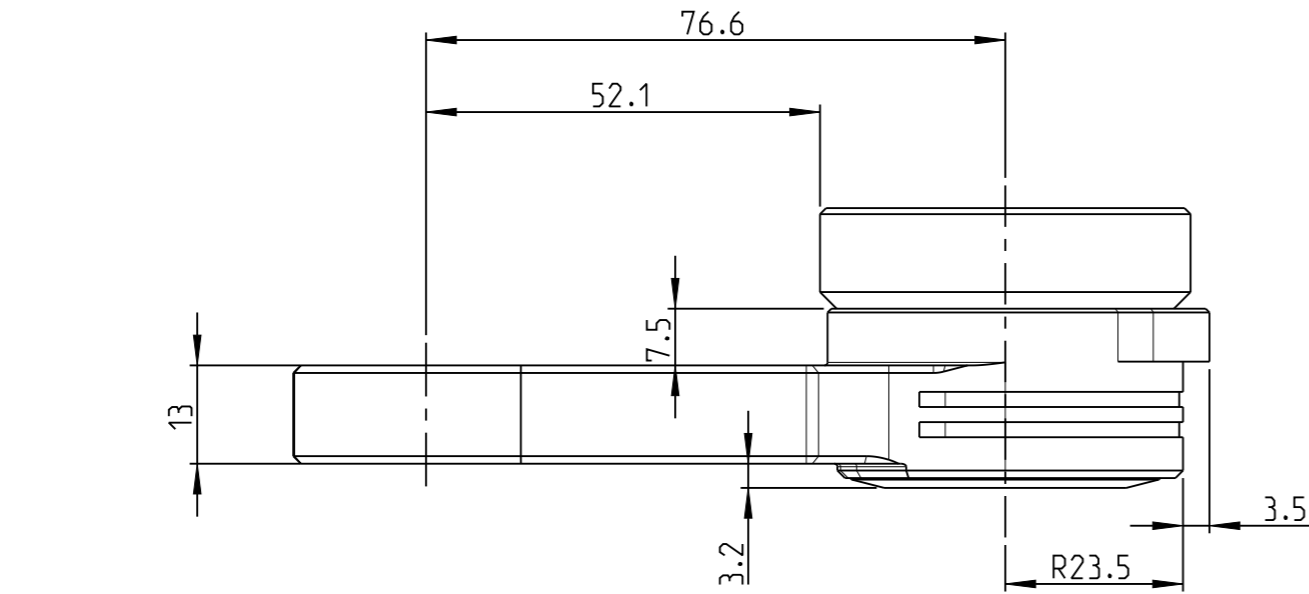

Input size	Square 1/2"
Gear stages	3
Input gear rotational direction	CW
Theoretical efficiency	0.77
Gear ratio	1.00
Max output torque	51.00 Nm
Max input torque	66.30 Nm
Approximate weight	0.7 kg
Max hex output size A/F	17 mm

SALTUS	Name	GFA-00T-C-70-18-13-3
	Designation	3512180085

proprietary document. Not to be used in any way without our consent.

PART	Status	Rev./Iter
GFA-00T-70-18-13-N01P	In Work	0.0
Drawing	Status	Rev./Iter
GFA-00T-70-18-13-N01P		0.0

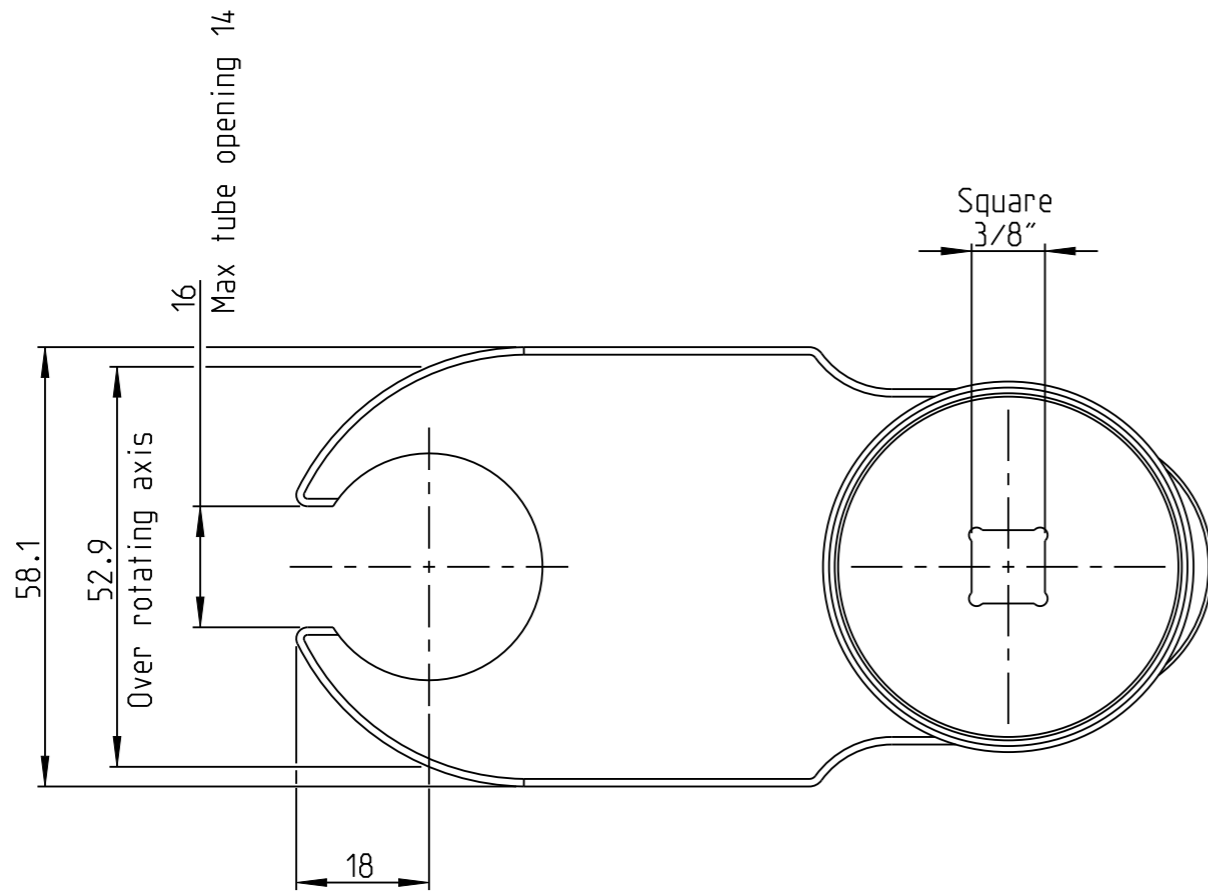
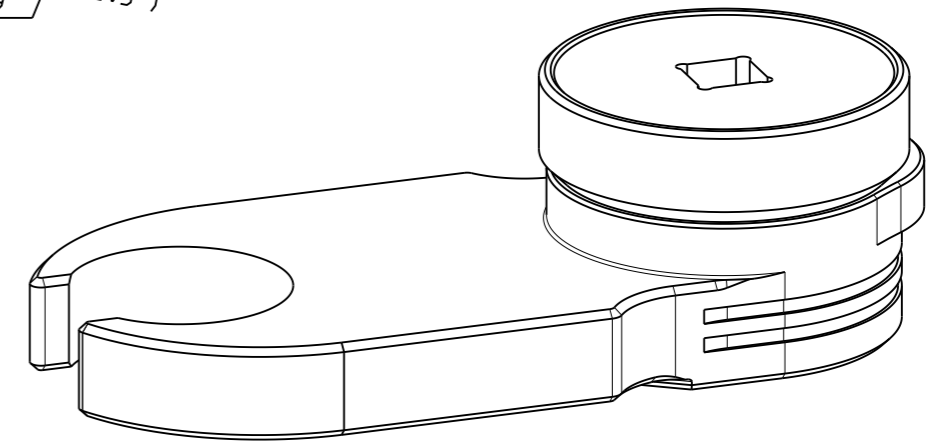
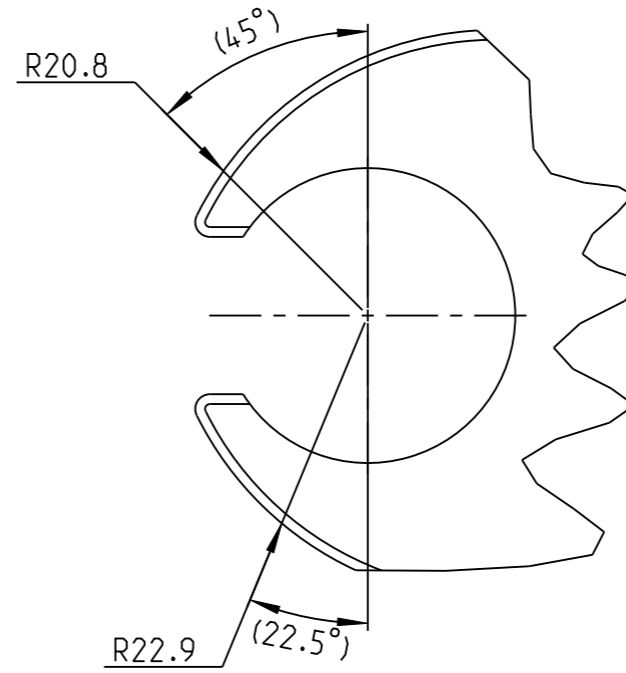
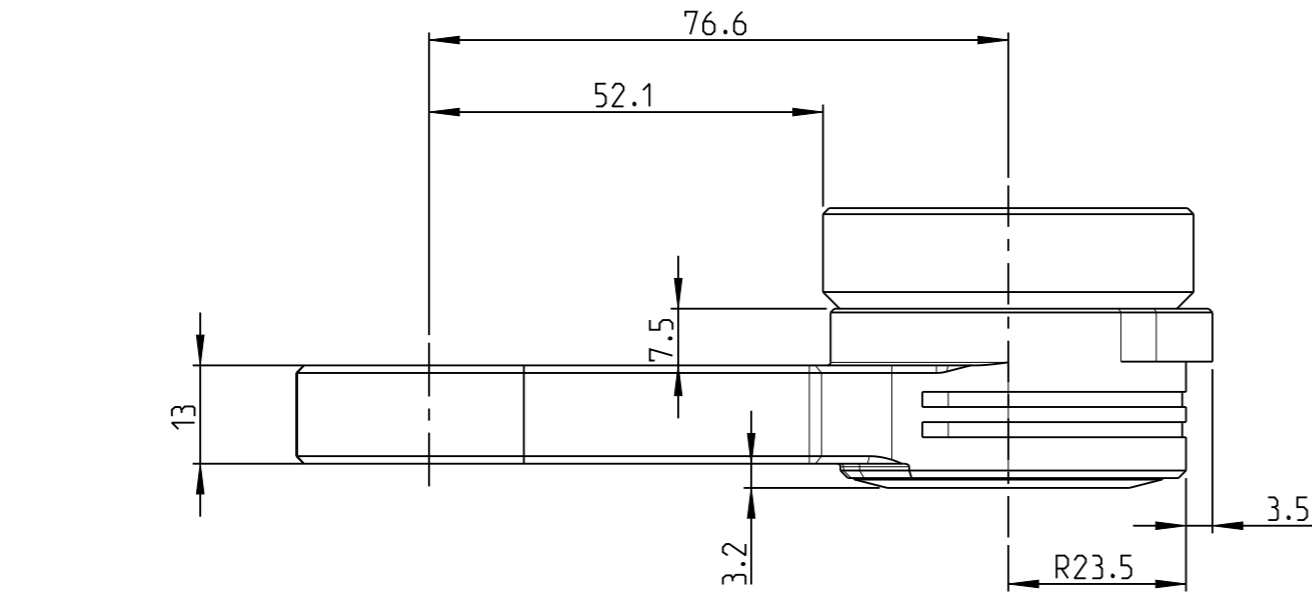

Input size	Square 3/8"
Gear stages	3
Input gear rotational direction	CW
Theoretical efficiency	0.77
Gear ratio	1.00
Max output torque	51.00 Nm
Max input torque	66.30 Nm
Approximate weight	0.71 kg
Max hex output size A/F	17 mm

SALTUS

Name	GFA-00T-B-70-18-13-3
Designation	3512180086

PART	Status	Rev./Iter
GF A-00T-70-18-13-N01P	In Work	0.0
Drawing	Status	Rev./Iter
GF A-00T-70-18-13-N01P		0.0

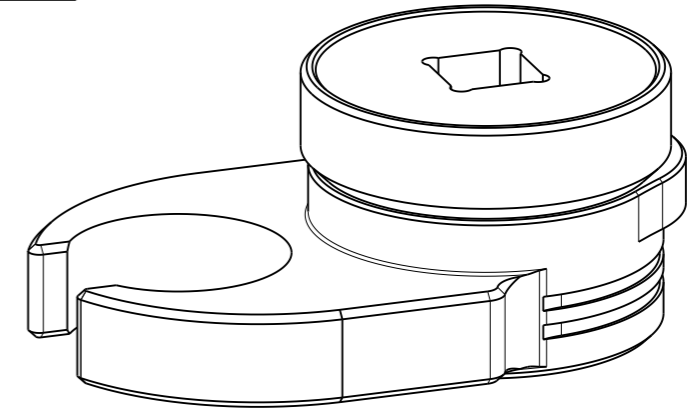
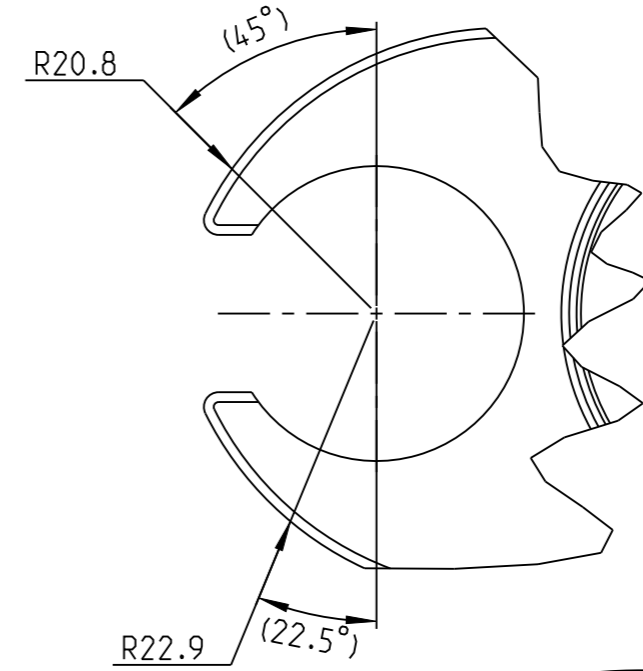
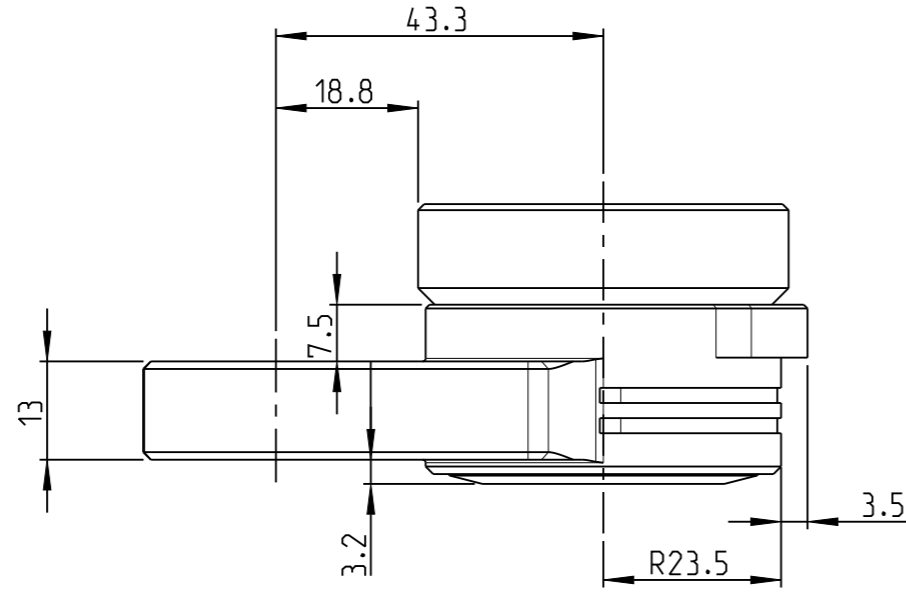
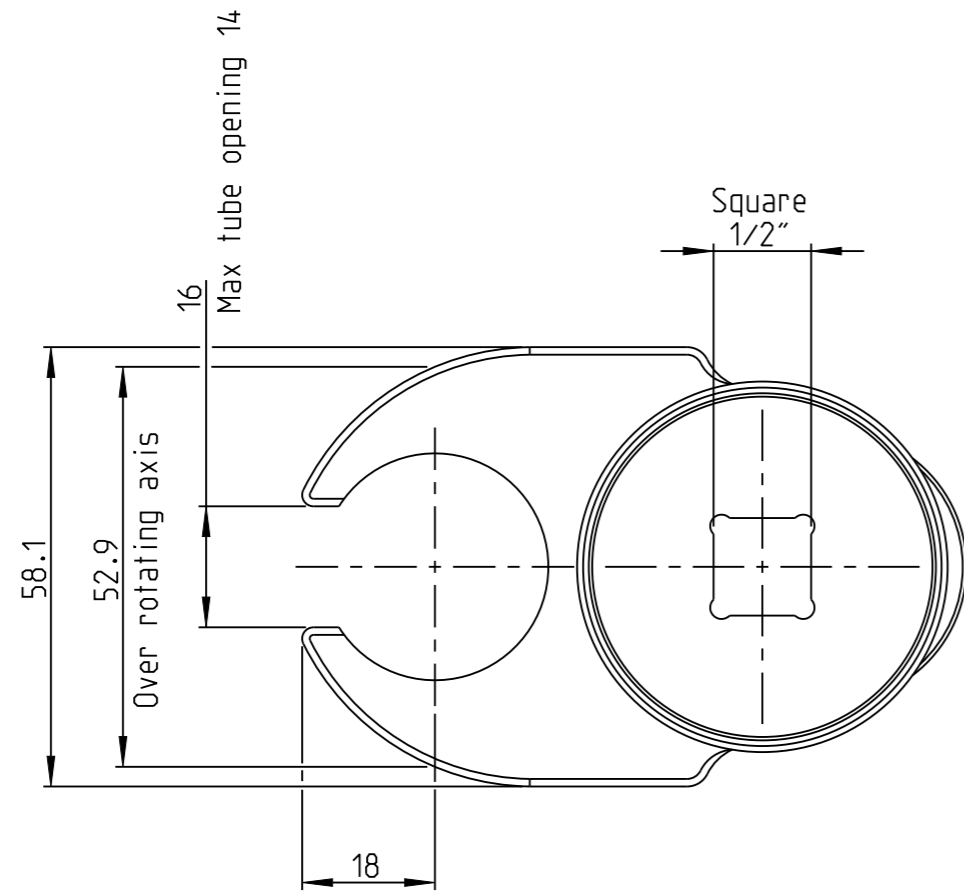

Input size	Square 1/2"
Gear stages	2
Input gear rotational direction	CCW
Theoretical efficiency	0.82
Gear ratio	1.00
Max output torque	51.00 Nm
Max input torque	62.20 Nm
Approximate weight	0.54 kg
Max hex output size A/F	17 mm

SALTUS	Name	GF A-00T-C-70-18-13-2
	Designation	3512180087

proprietary document. Not to be used in any way without our consent.

PART	Status	Rev./Iter
GFA-00T-70-18-13-N01P	In Work	0.0
Drawing	Status	Rev./Iter
GFA-00T-70-18-13-N01P		0.0

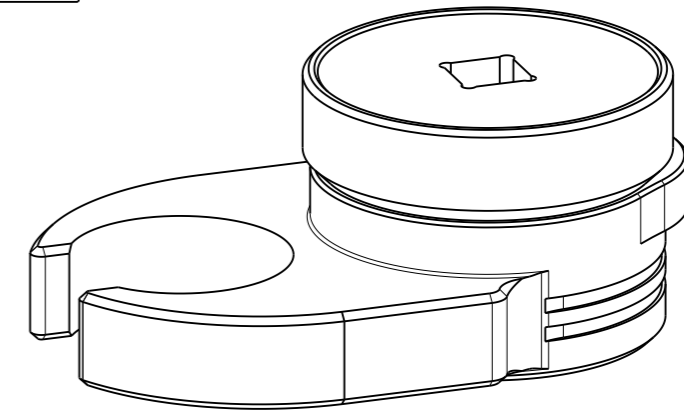
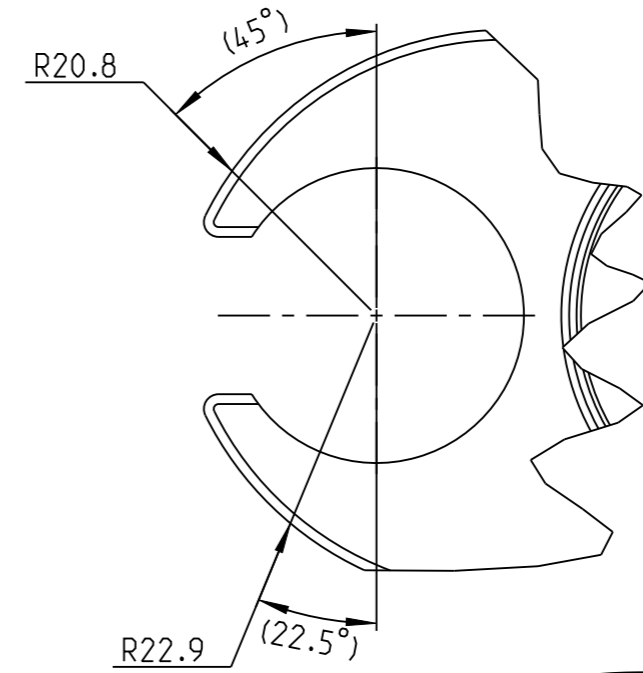
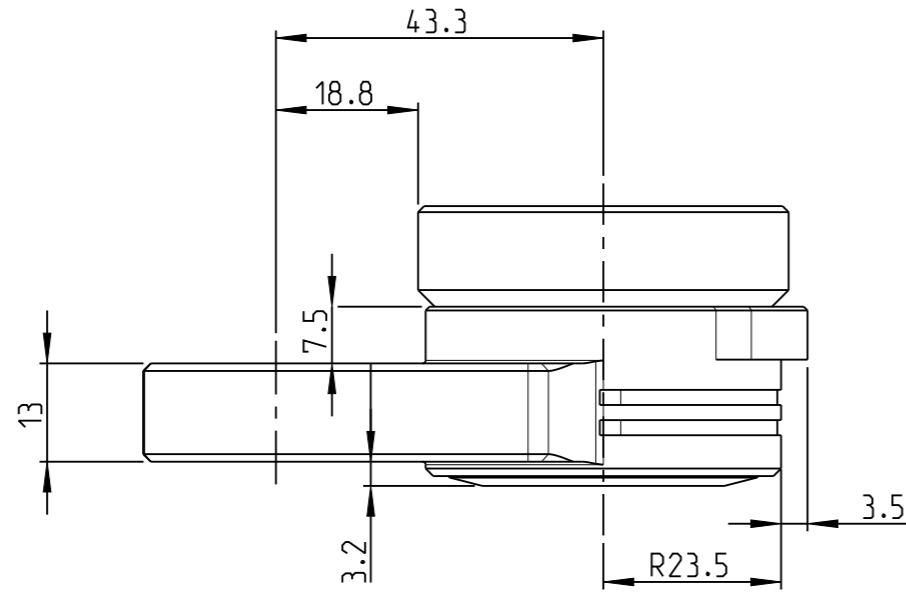
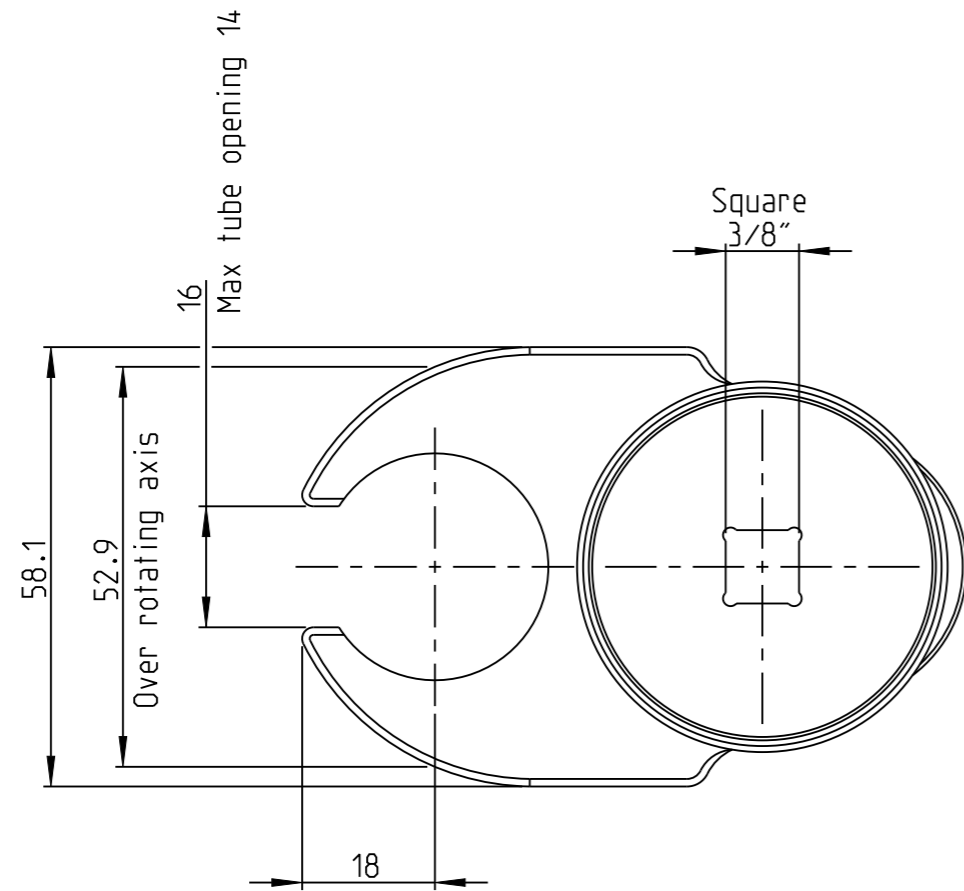

Input size	Square 3/8"
Gear stages	2
Input gear rotational direction	CCW
Theoretical efficiency	0.82
Gear ratio	1.00
Max output torque	51.00 Nm
Max input torque	62.20 Nm
Approximate weight	0.55 kg
Max hex output size A/F	17 mm

SALTUS	Name	GFA-00T-B-70-18-13-2
	Designation	3512180088

proprietary document. Not to be used in any way without our consent.