

| | | | | | |
|---------|-----------------|--------|---------|-------------|-----|
| PART | GFA-COT-81-NCIP | Status | In Work | Rev. / Iter | 0.8 |
| Drawing | GFA-COT-81-NCIP | Status | | Rev. / Iter | 0.2 |

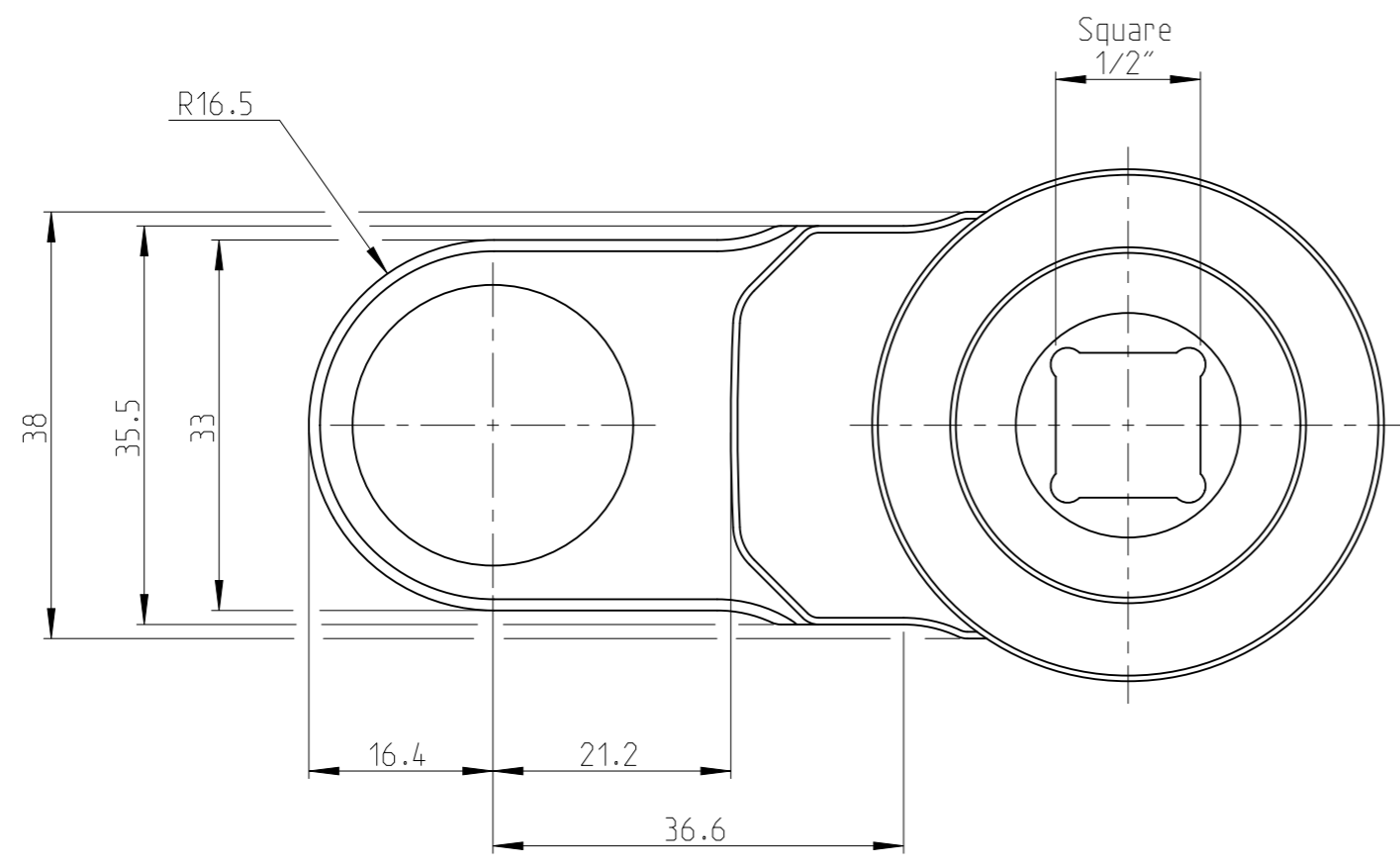
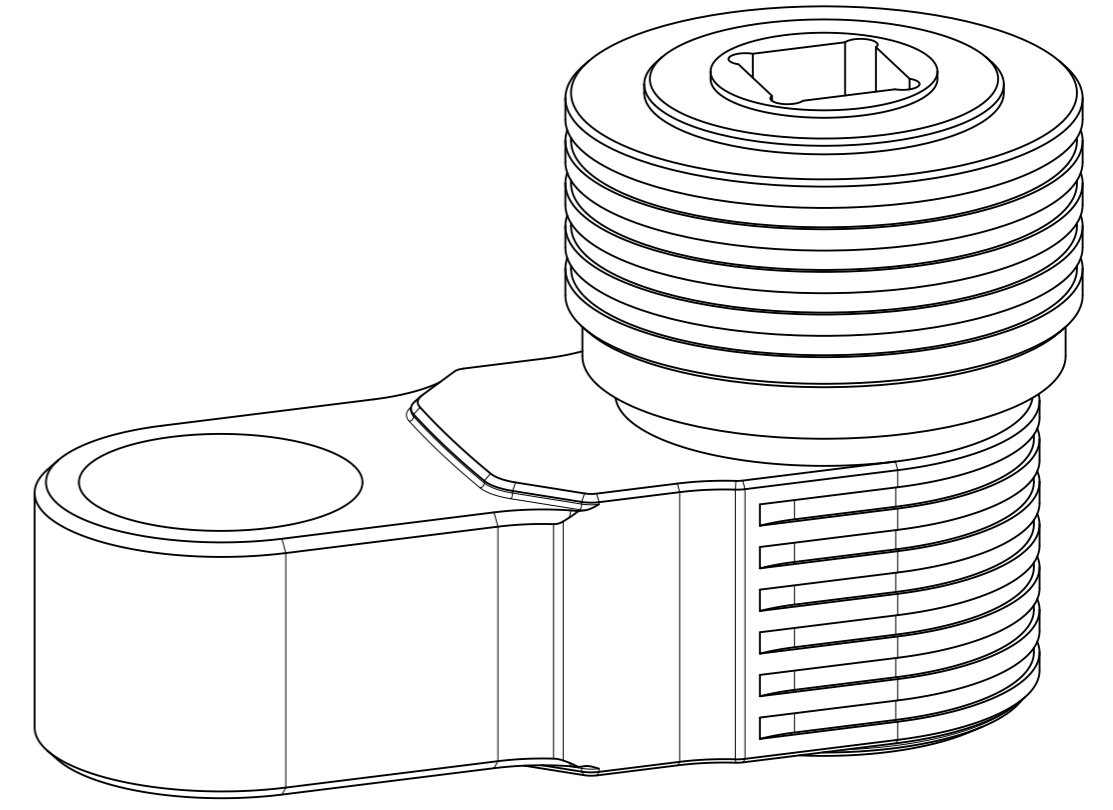
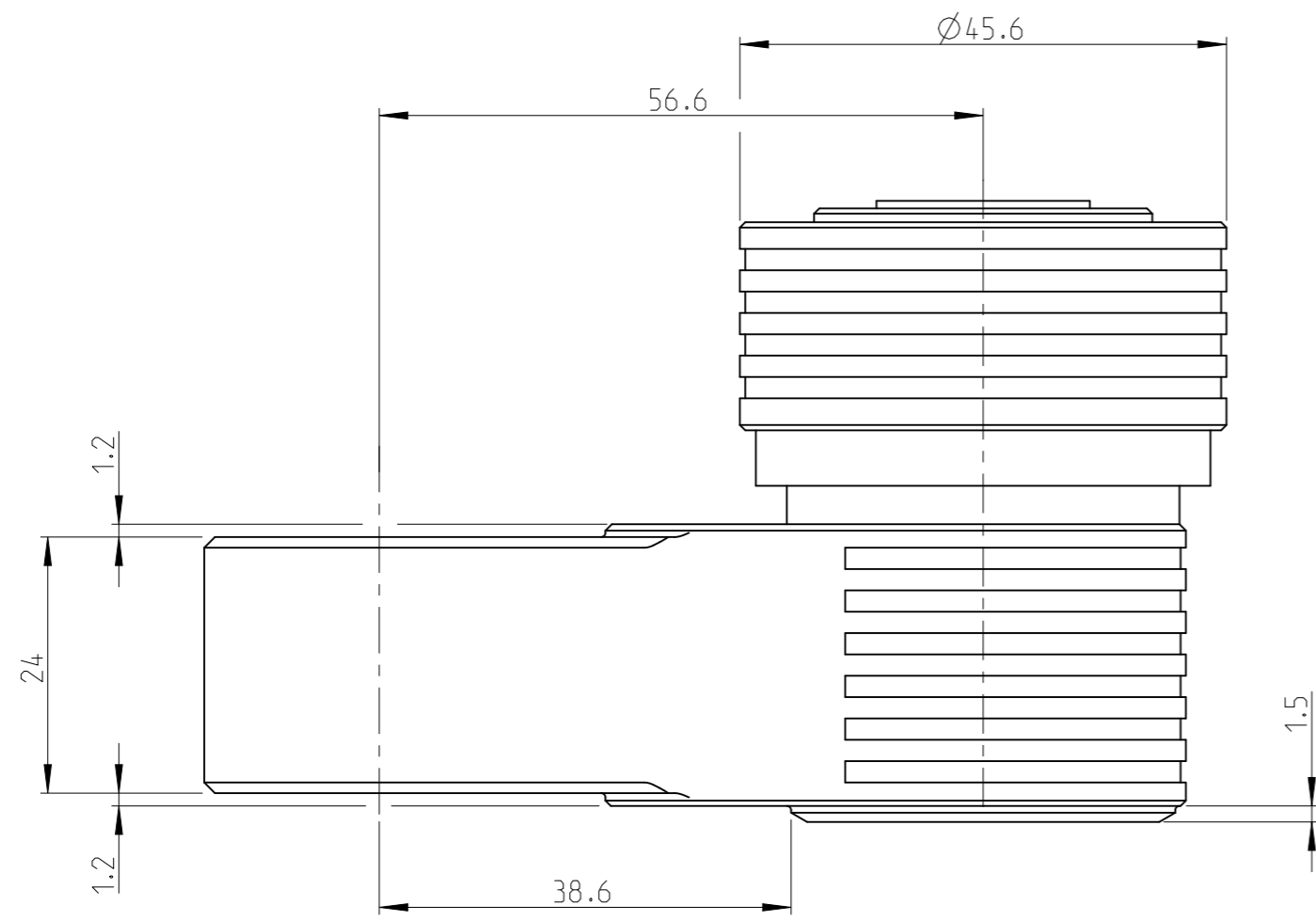

| | |
|-------------------------|-------------|
| Input size | Square 1/2" |
| Gear stages | 2 |
| Theoretical efficiency | 0.85 |
| Gear ratio | 1.18 |
| Max output torque | 75.00 Nm |
| Max input torque | 74.8 Nm |
| Approximate weight | 0.63 kg |
| Max hex output size A/F | 19 mm |

| | | |
|---------------|-------------|----------------------|
| SALTUS | Name | GFA-COT-C-81-16-24-2 |
| | Designation | 3512170080 |

proprietary document. Not to be used in any way without our consent.

| | | | |
|------|-----------------|-----------------|-------------|
| PART | GFA-COT-81-NCIP | Status | Rev. / Iter |
| | Drawing | GFA-COT-81-NCIP | Rev. / Iter |

| | |
|--------|-------------|
| Status | Rev. / Iter |
| Status | Rev. / Iter |

proprietary document. Not to be used in any way without our consent.

1 2 3 4 5 6 7 8 9 10

A
B
C
D
E
F
G

| | |
|---------------|-------------|
| SALTUS | Name |
| | Designation |

| | | | | | |
|------|-----------------|-----------------|---------|-----------|-----|
| PART | GFA-COT-81-NCIP | Status | In Work | Rev./Iter | 0.8 |
| | Drawing | GFA-COT-81-NCIP | Status | Rev./Iter | 0.2 |

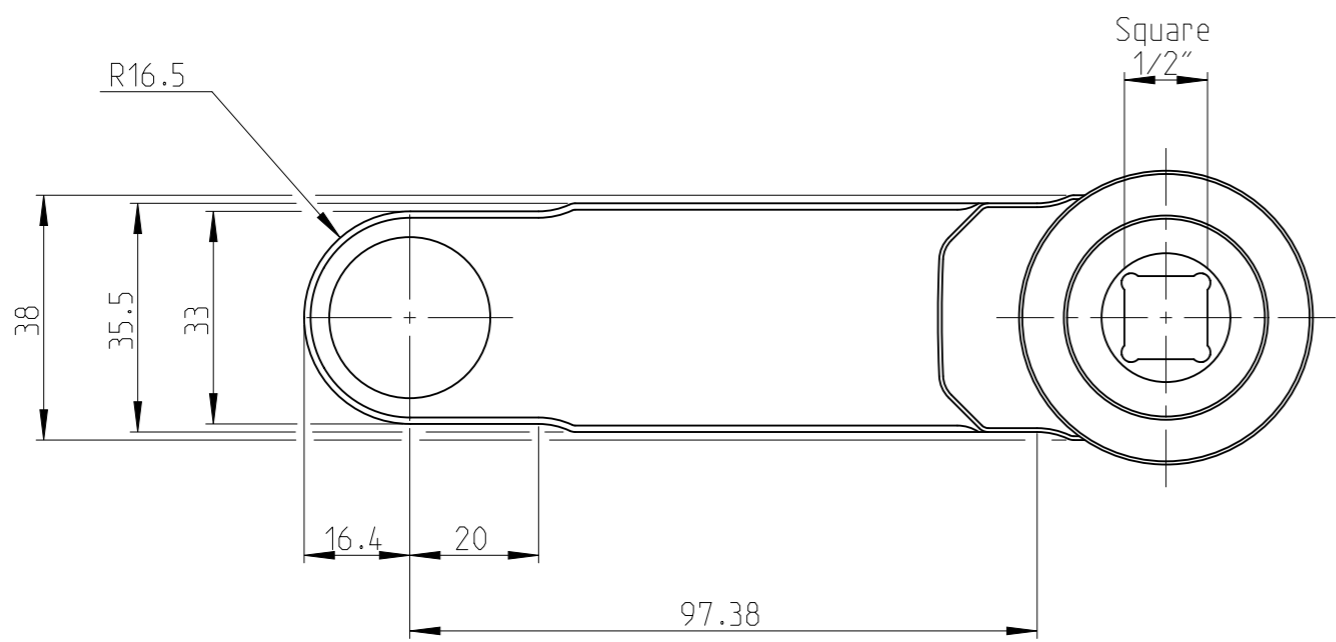
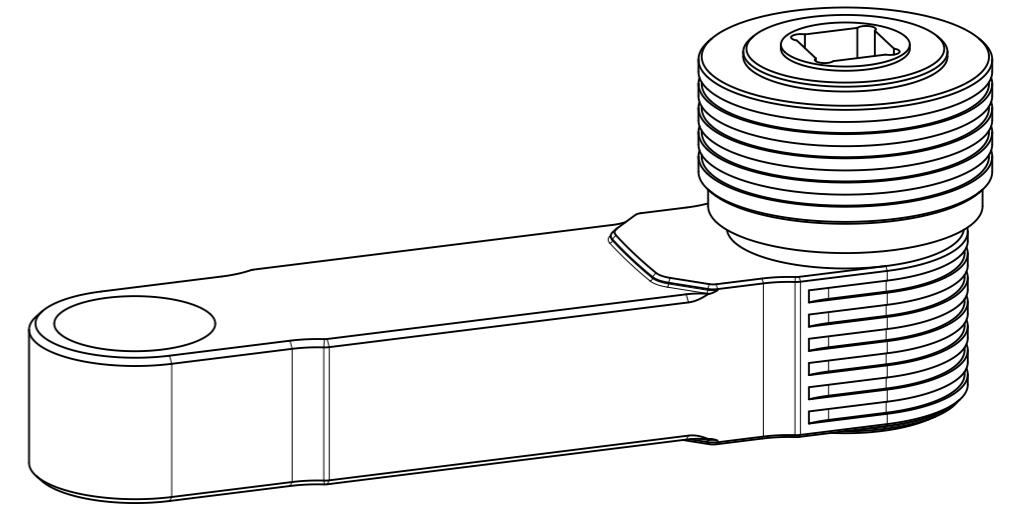
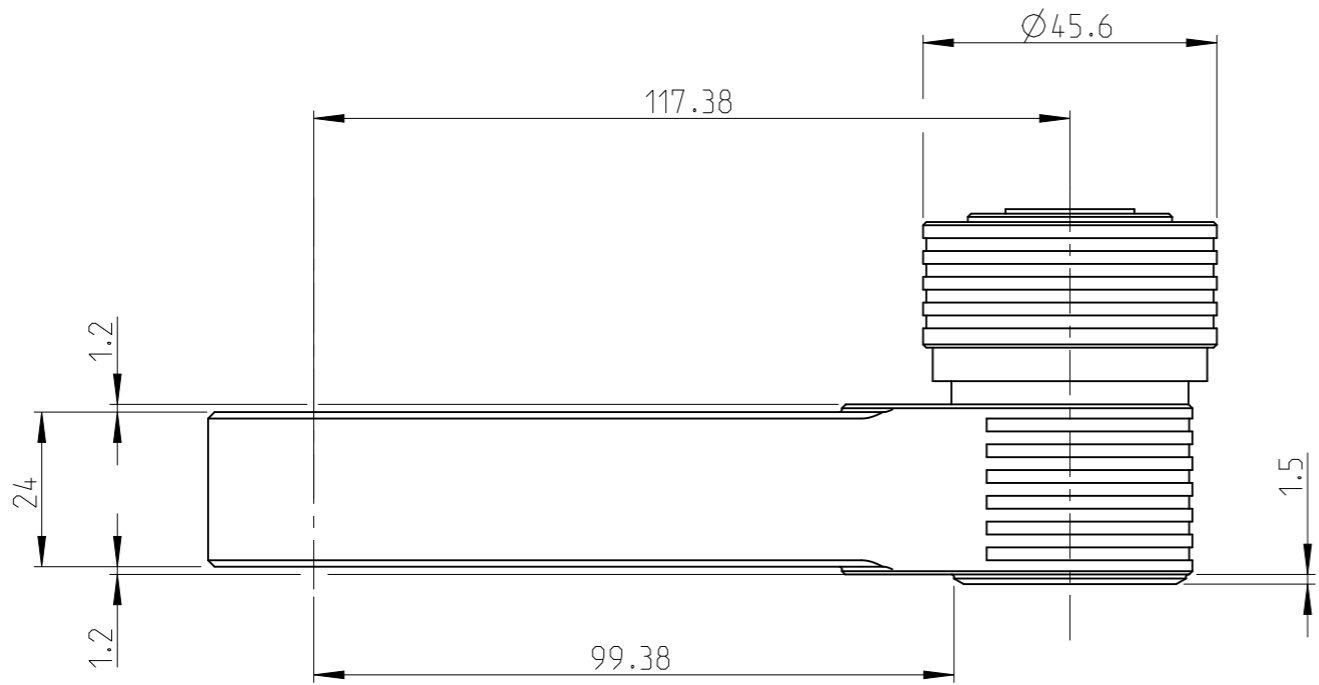

| | |
|-------------------------|-------------|
| Input size | Square 1/2" |
| Gear stages | 4 |
| Theoretical efficiency | 0.75 |
| Gear ratio | 1.18 |
| Max output torque | 75.00 Nm |
| Max input torque | 84.7 Nm |
| Approximate weight | 0.98 kg |
| Max hex output size A/F | 19 mm |

proprietary document. Not to be used in any way without our consent.

| | | |
|---------------|-------------|----------------------|
| SALTUS | Name | GFA-COT-C-81-16-24-4 |
| | Designation | 3512170081 |