

Atlas Copco



Ready to go

Stage V compliant  
small air compressors

# Stage V compliant small air compressors

## Stage V compliant

The introduction of Stage V in smaller diesel air compressors, has a significant impact on the entire range. Stage V compliance reduces CO<sub>2</sub> and NO<sub>x</sub> emissions to the specified levels. In addition to reduced emissions; **fuel efficiency increases with 25%**; keeping your operational costs under control.

## Enter the digital age

**Intelligent controllers** ease operation, increase utilization rate and boost energy efficiency. All this compressor data can also be accessed remotely through Fleetlink. All compressors with electronic engines (over 19 kW) have an integrated controller: the easy-to-use Xc1004 or the advanced Xc2003. The last one also enables PACE and ECO-Mode functionalities to consequently boost **utilization** and **energy savings** during idling situations.

## The two-tooler with the best return on investment

One 3 m<sup>3</sup>/min compressor powers 2 handheld tools. With only 1 compressor to purchase, transport, fuel and service, you enjoy a faster return on your investment. Thanks to our famous compressor element, we could build a **3m<sup>3</sup>/min compressor with an engine under 19 kW**, and therefore without exhaust after-treatment system. For even more flexibility on your work site, you can add an **optional built-in generator**.

## Signature reliability

All standard models under 750 kg for **easy transport** without a special drivers license, PE protection for increased reliability and resale value, service in under an hour for increased uptime. None of these known and appreciated 8 series benefits have been sacrificed with the introduction of Stage V.

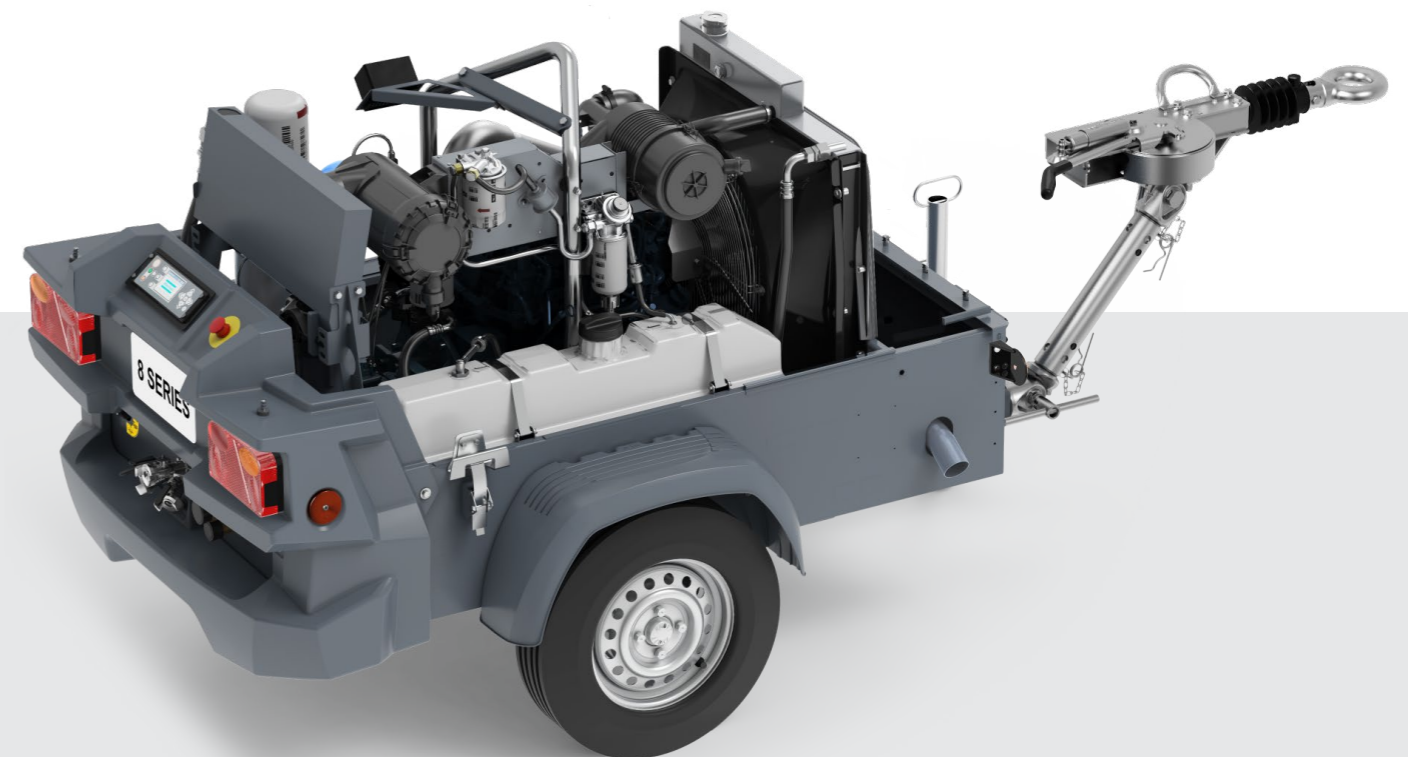

# Features and benefits



## PE hood and back baffle

The full PE hood and bumper protect your investment. No matter the circumstances on site or during transport, the PE material remains in perfect condition; increasing the resale value of your asset.



## Xc2003 controller with PACE and ECO-mode

- Gain full control of your compressor. The easy to use interface of the Xc2003 controller allows for easy control of your compressor but also unlocks some powerful features.
- The integrated PACE module (Pressure Adjusted through Cognitive Electronics) boosts the versatility of your compressor. In just 3 simple steps, you set the pressure level of your compressor to your requirements. Your utilization rate is boosted as one compressor with PACE can handle multiple applications; from paint spraying, over powering handheld tools to shotcreting.
- Most compressors are running idle several times per day: for changing tools, breaks from operators. These compressors used to go into unload, keeping under pressure until the operation would resume. With ECO-Mode, the compressor will go to no load in these situations, saving 50% energy. And when the air demand returns, your compressor is automatically restarted.
- No matter the circumstances, the Xc2003 controller's reliability is guaranteed thanks to the IP65 rated protection from dust and water.

(The Xc2003 controller is available on selected models)

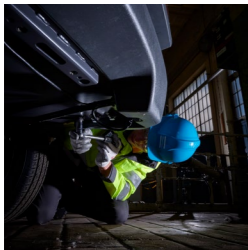

## 110% Spillage free frame

No matter the circumstances, your compressor can contain 110% of all fluids used in the process. As a consequence, there is no risk to pollute the environment with any liquid spills. Maintenance is efficient thanks to central drains.



## Spin on filters

Service can be completed in under an hour without the need for special tools thanks to Atlas Copco's spin on filters.



## Lifting beam

The lifting beam is certified to lift 4 times the weight of the compressor.

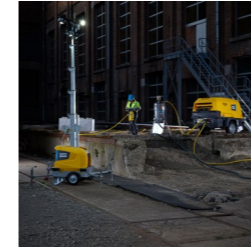

## Integrated generator

There is no need to roll in a generator for small power needs on site. Whether you need to light a cabine, power electric tools or a light tower, the integrated generator increases the efficiency of your compressor on site.

(available on selected models)

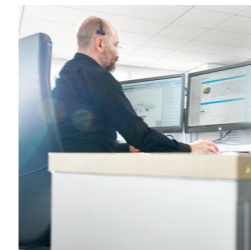

## Fleetlink

- Remote Monitoring, Anytime, Anywhere.
- All data available on your controller, can be accessed remotely.
- Increase line of sight on your equipment for more accurate, fast and smart business decisions.
- Maximize fleet productivity and uncover potential for optimization and savings.
- Use the Atlas Copco FleetLink Dashboard, or integrate seamlessly Fleet data into 3<sup>rd</sup> party software via API.

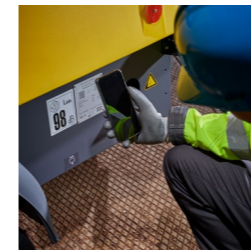

## QR code

- Scan the unique QR code to access a wealth of information, specified for that specific unit: dedicated parts lists, instructions, quick service tips and videos, certificates.
- Download the Atlas Copco Power App for easy access.



## C3 certified anti-corrosion frame

The single sheet reinforced frame is protected with 3 layer anti-corrosion paint.

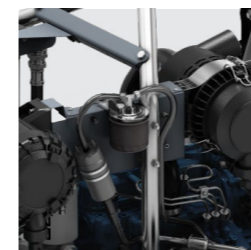

## Anti-airlock system

Calling the service technician because your machine is running dry? That's a thing from the past. Thanks to the anti-airlock system, the 8 series can prime itself removing air from the fuel lines.

# Technical data

Technical data	Value	XAS 38	XAS 48	XAS 48-7 G	XAS 58-7	XAS 58-7 G	XAS 48-7 G	XAS 68-10	XAS 68-7 G	XAS 68-12 PACE	XAS 88-7	XAS 88-7 G	XAS 88-10 PACE
Nominal effective working pressure	bar (g)	7	7	7	7	7	7	10.3	7	5 - 12	7	7	5 - 10.3
	psi (g)	100	100	100	100	100	100	150	100	73 - 175	100	100	73 - 150
Actual Free Air Delivery (no aftercooler)	m³/min	2	2.5	2.5	3	3	2.5	3.5	3.5	3.5 - 3.25	5	5	5 - 3.5
	l/s	33	42	42	50	50	42	58.9	58.7	58.6 - 54.4	82	82	82 - 56.3
	cfm	70	89	89	106	106	89	125	125	125 - 115	174	174	174 - 120
Max.sound power level (Lw @2000/14/EC)	dB(A)	97	98	98	95	95	98	98	98	98	98	98	98
Max.sound pressure level at 10m (Lp)	dB(A)	69	70	70	67	67	70	70	70	70	70	70	70
Max ambient temperature with/without aftercooler (at sea level)	°C	45 / 50	45 / 50	45 / 50	45 / 50	45 / 50	45 / 50	45 / 50	45 / 50	45 / 50	45 / 50	45 / 50	45 / 50
Min ambient temperature with/without Cold Start	°C	-20 / -10	-20 / -10	-20 / -10	-20 / -10	-20 / -10	-20 / -10	-20 / -10	-20 / -10	-20 / -10	-20 / -10	-20 / -10	-20 / -10
<b>Alternator</b>													
Alternator power	kVA			6 or 6.5		6 or 6.5	12		6 or 6.5 or 12			6.5 or 9	
Alternator output voltage	V			230/400 or 110		230/400 or 110	230/400		230/400 or 110			110 or 230/400	
<b>Engine</b>													
Engine brand		Kubota	Kubota	Kubota	Kubota	Kubota	Kubota	Kubota	Kubota	Kubota	Kubota	Kubota	Kubota
Engine model		D722	D902	D902	D1105	D1105	V1505-CR-T	V1505-CR-T	V1505-CR-T	V1505-CR-T	V1505-CR-T	V1505-CR-T	V1505-CR-T
Emission stage		EU Stage V	EU Stage V	EU Stage V	EU Stage V	EU Stage V	EU Stage V	EU Stage V	EU Stage V	EU Stage V	EU Stage V	EU Stage V	EU Stage V
Engine power at full load engine speed	kW	14.9	18.5	18.5	18.5	18.5	33	33	33	33	33	33	33
Number of cylinders		3	3	3	3	3	4	4	4	4	4	4	4
Full load/nominal speed	rpm	3400	3400	3400	3000	3000	3000	3000	3000	3000	3000	3000	3000
Unload speed	rpm	2000	2000	1850	2400	2400	1800	1800	1800	1800	1800	1800	1800
Capacity of oil sump	l	3.8	3.8	3.8	4.5	4.5	5.5	5.5	5.5	5.5	5.5	5.5	5.5
<b>Dimensions</b>													
Box (length x width x height)	mm	1570 x 1060 x 990	1570 x 1060 x 990	1940 x 1180 x 1150	1940 x 1180 x 1150	1940 x 1180 x 1150	1940 x 1180 x 1150	1940 x 1180 x 1150	1940 x 1180 x 1150	1940 x 1180 x 1150	1940 x 1180 x 1150	1940 x 1180 x 1150	1940 x 1180 x 1150
Box weight	kg	440	440	650	650	650	650	650	650	650	650	650	650
Undercarriage (length x width x height)	mm	1960 x 1230 x 1250	1960 x 1230 x 1250	2290 x 1350 x 1400	2290 x 1350 x 1400	2290 x 1350 x 1400	2290 x 1350 x 1400	2290 x 1350 x 1400	2290 x 1350 x 1400	2290 x 1350 x 1400	2290 x 1350 x 1400	2290 x 1350 x 1400	2290 x 1350 x 1400
Undercarriage weight	kg	500	500	749	749	749	850	749	850	749	749	850	749

## Standard features

- PE hood and back baffle
- 110% spillage-free frame
- Spin-on filters
- C3 certified anti-corrosion frame
- Anti-airlock system
- Starter motor protection system
- Digital controller Xc1004 (on XAS 68-10 and XAS 88-7)
- Digital controller Xc2003 (on XAS 48-7G, XAS 68-7 G, XAS 68-12 PACE, XAS 88-7 G and XAS 88-10 PACE)
- Controller lock-out switch

## Options

- Built-in generator
- After-cooler + water separator (+ optional reheater, bypass valve, non-return valve)
- Toolbox
- Lubricator
- Cold start
- Fleetlink

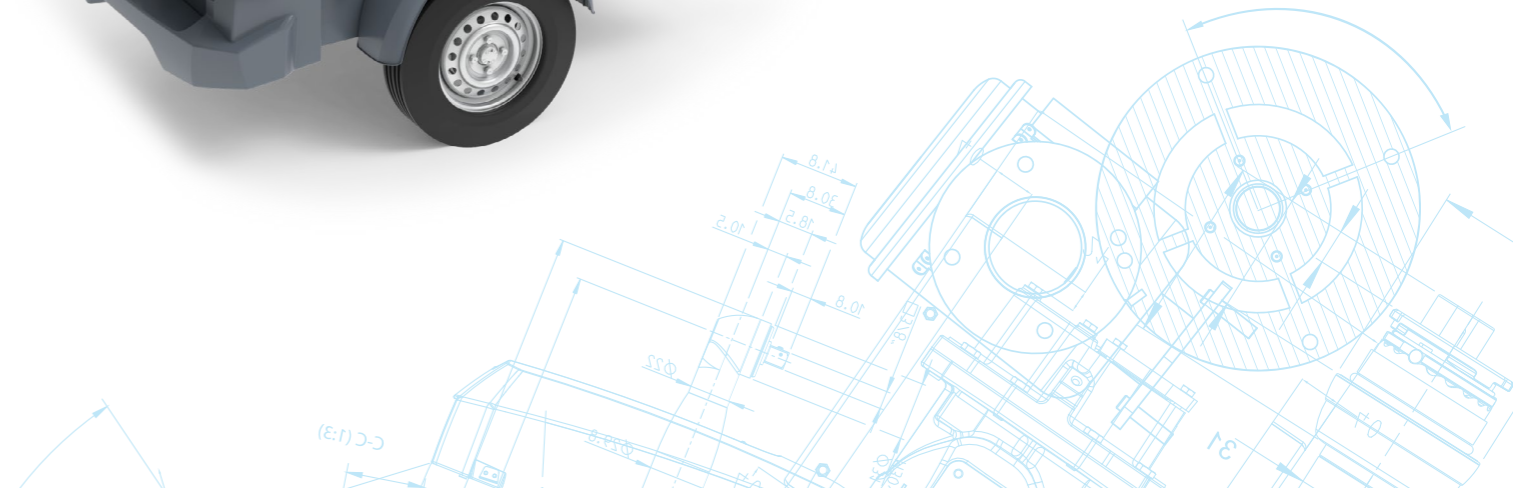
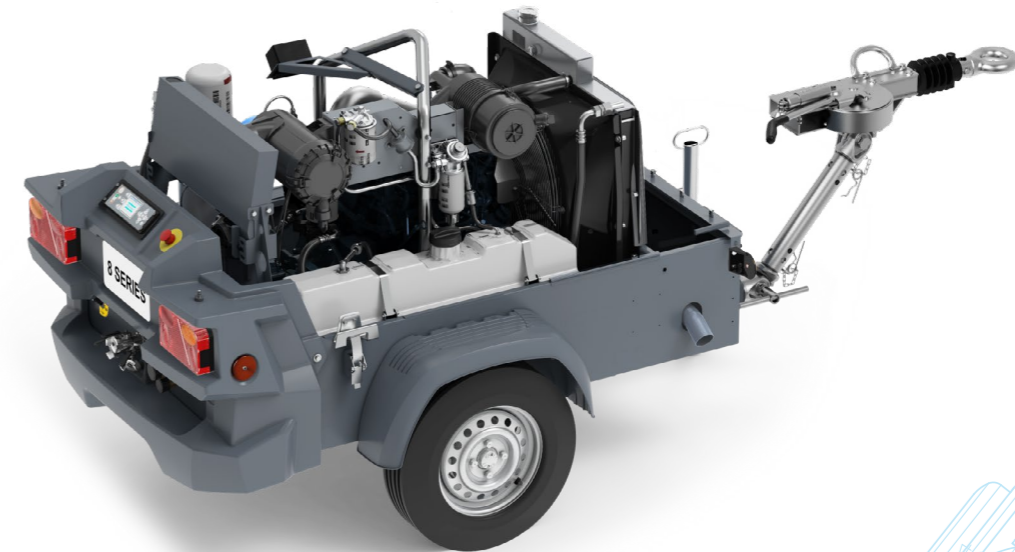

# Power Technique Solutions Portfolio

Atlas Copco's Power Technique Business Area has a forward-thinking philosophy. For us, creating customer value is all about anticipating and exceeding your future needs – while never compromising our environmental principles. Looking ahead and staying ahead is the only way we can ensure we are your long term partner.

## Air compressors

### Ready to go



- 1-5 m<sup>3</sup>/min
- 7-12 bar

### Versatility



- 5.5-22 m<sup>3</sup>/min
  - 7-20 bar
- \*Diesel and electric options available

### Productivity partner



- 19-116 m<sup>3</sup>/min
- 10-345 bar

## Handheld tools

### Pneumatic tools



- Breakers (2,5 – 40 kg)
- Rockdrills (5 – 25 kg)
- Underground Rock Drills
- Additional Air Tools

### Hydraulic tools



- Breakers (11 – 40 kg)
- Additional Hydraulic Tools
- Powerpacks

### Petrol engine driven tools



- Breakers & Tie Tampers (25 kg)
- Rockdrills (23 Kg)

### Generators



- Portable
- Mobile
- Industrial

\*Multiple configurations available to produce power for any size application

### Light towers



- Diesel LED and MH
- Electric LED
- Battery LED

### Dewatering pumps



- Submersible
- Surface
- Small portable

\*Diesel and electric options available

Photos and illustrations contained herein might depict products with optional and/or extra components which are not included with the standard version of the product and, therefore, are not included in a purchase of such product unless the customer specifically purchases such optional/extra components. We reserve the right to change the specifications and design of products described in this literature without notice. Not all products are available in all markets.