

The Atlas Copco logo, consisting of the brand name in a white serif font centered between two horizontal white bars, is positioned in the top left corner of the image. The background of the entire page is a close-up photograph of several industrial air filters. One filter in the foreground is white with a red stripe and a black label that reads "Atlas Copco ORIGINAL PART 1613 6105 00 Eq. 2 MAX. 15 BAR" and "1608". Other filters are shown in shades of pink and orange, all with pleated paper elements. A blue technical drawing of a filter housing is overlaid in the bottom right corner.

Atlas Copco

Why Use Genuine Filters?

Protect your investment, use genuine filters to minimize your cost of ownership

Genuine Filters

Only genuine filters guarantee the maximum element efficiency and longer lifetime together with the genuine Atlas Copco fluids.

Our genuine Atlas Copco filters and fluids are manufactured to the same exact standards as our equipment and have passed the same endurance tests.

Genuine filters avoid problems such as a poor sealing between the filter body and the engine or the quick deterioration of the paper element inside the filter. Our fluids extend the life time of the parts due to its matchless anti oxidation properties and also maximize the efficiency of your compressor element.

Using our genuine Atlas Copco filters and fluids has proven to be the best way to protect your investment from poor performance and to ensure your machine is working according to the original factory specifications. In this brochure, we will be sharing the real test results and facts with you to prove this.

Benefits

- Reduced operating costs
- Low equipment downtime
- Longer service life
- Best optimized filtration performance
- Increased resale value

Increase your operational efficiency through proactive maintenance

With Atlas Copco's wide range of high-quality genuine parts and highly qualified and skilled technicians, your equipment will be in top condition, resulting in:

- Longer equipment uptime
- Less expensive repairs
- Lower fuel cost

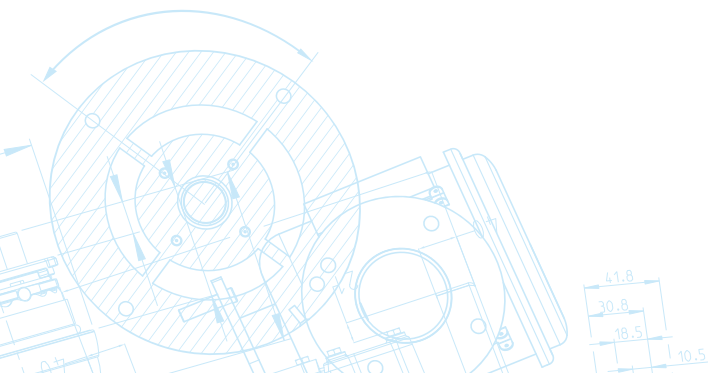

Why Air filtration?

The air in the construction working environment is full of contaminants and the air filters are the first line of contact and resistance to contamination. The most expensive, components – (diesel engine, compressor) have air inlet system that need quality air (no contaminants) for combustion, air compression. Quality of the air has a major role on each component operation, performance, wear and lifetime.

- Contaminants will reduce the fluid and lubricants characteristics and performance, causing accelerated oil aging (engine oil, compressor oil) and increased development of acids that affect the protection of metallic components.
- Rotors and housing run with tight clearances between them (<0.04 mm) (<0.002 inches).
- Dirt between rotors and housing results in damage to the rotors, leading to less compressed air delivered and higher fuel consumption.

Unfiltered Dust will reduce the lifetime and the efficiency of the compressor element, oil separator element and oil.

Why Oil filtration?

- Dust and dirt will damage the rotors and housing, resulting in inferior performance.
- Dust and dirt will damage the bearings and bearing housing.
- Bearing wear will lead to increased rotor contact, the compressor element will fail.
- The efficiency and the lifetime of the oil and also the element will be reduced.

Why air/oil separation?

- Reduces oil consumption and service costs by keeping the oil in the oil circuit.
- Reduces fuel consumption.
- Limits oil contamination and delivers clean air.

Why fuel filtration?

- Dirt and water in fuel can seriously harm fuel pumps and fuel injectors.
- Water in the fuel will reduce the power output of the engine.
- Fuel quality varies depending on the local refining process and transport conditions.

There are visible and also invisible micro structural differences between the filters and both have a direct impact on the lifetime of the filters and ultimately to your cost of ownership. Hence, we believe it is necessary to understand what those differences are in detail so as to grasp the importance of using genuine filters.

1. Visible differences

The different properties of the filters that can easily be detected by the appearance of the filters. Superior visible physical properties of a filter will always result in huge performance differences when it comes to dust holding capacity, filtration efficiency and restriction level next to an inferior quality filter.

Below are the most important visible differences:

- **Filter media**
The mechanical strength or the uniformity of the pleats.
- Filter Media Quality
- Stabilization
- **Sealing**
The quality of avoiding leakages.
- **Flame Protection or conductivity**
Critical property to avoid fires.

2. Invisible differences

Even though the appearance and the filter media of the filters are the same, the test results can still be completely different due to different micro structure of the filters. Different micro filter structure result in different performances in terms of dust holding capacity, filtration efficiency and restriction level.

Below are the most important invisible differences:

- **Dust holding capacity**
The capacity of the filter to hold dust.
- **Filtration Efficiency**
Efficiency to separate dust out of the filtration system.
- **Restriction Level**
The pressure differences due to the filtration process.

Filter Performance Optimization Challenge

Same filter media does not necessarily mean the performance of the filter will be the same. There is always an interrelation between dust holding capacity, filtration efficiency and restriction level of a filter. Providing that the same type of filter media is used, one parameter cannot be improved without affecting or limiting the other. In this case, the main challenge is to achieve optimum balance between those parameters for the compressors. Atlas Copco offers the most optimum balance to maximize the performance of our compressor.

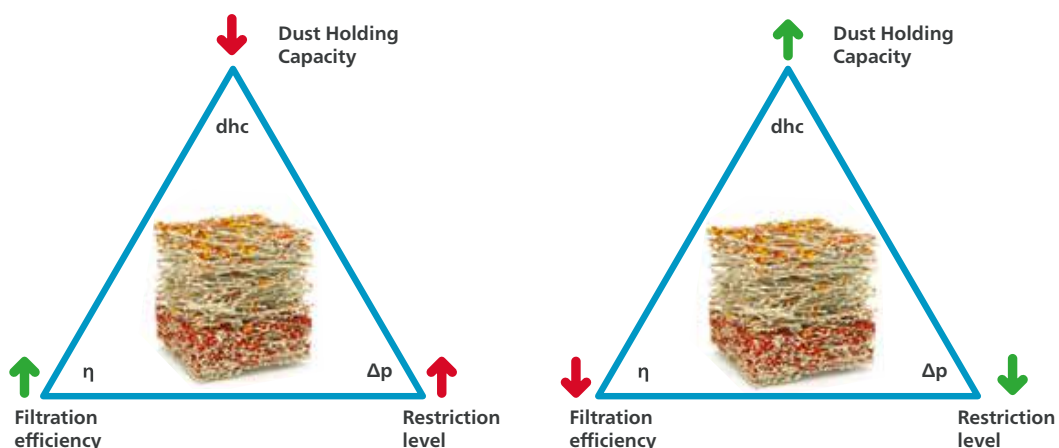

Optimum filter performance lies upon the optimization of three main criteria if same filter media is used

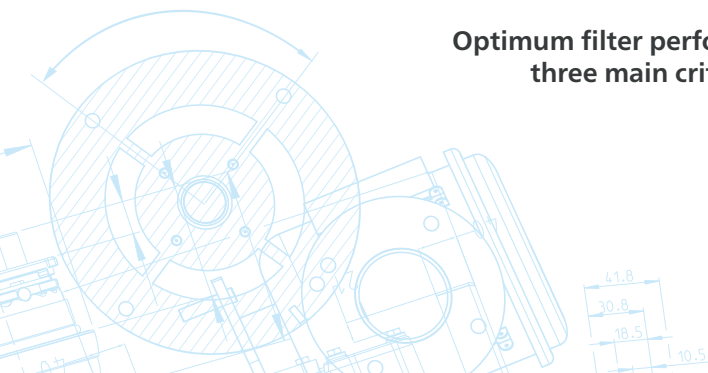

1. Visible differences

In order to shed light on physical differences, there are 3 important points requires investigation.

1. Filter Media

The mechanical strength and also the uniformity of filter pleats in the media is crucial for the lifetime of other components. The compressor is exposed to tough environmental conditions. The temperature and structure of the synthetic compressor oil can easily collapse the filter pre-maturely if the filter is only designed for engine oil filtration.

2. Sealing

If a pirate filter is using inferior quality of seals or bad gluing of the seal, unfiltered air might enter the compressor element. In such a case the separating capacity of the filter paper might be OK, but the overall separating performance of the filter is doubtful.



3. Fire Protection

Our Separator Filters are also electrically interconnected metallic parts to prevent electrostatic discharges and reduce the risk of internal fires.

Filter Media

Below are the different quality of filter media common in different industries.

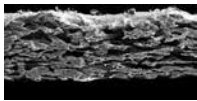
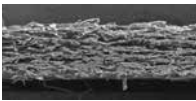
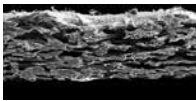
Air Filters

	Micrograde A-c 4(F1) cellulose	MICROGRADE A-C 4.2 (F1) (High performance cellulose F1)	MICROGRADE A-NF 6 (F1) (cellulose F1+nanofibers)	MICROGRADE A-NF 6.2 (F1) (high performance cellulose F1+nanofibers)
SEM Picture (Cross section)				
Fibre diameter	Cellulose fibers 15-40 µm	Cellulose fibers 15-40 µm & synthetic fibers 10-20 µm	Cellulose fibers 15-40 µm nanofibre coating 0.1-0.4 µm	Cellulose fibers synthetic fibers 15-40 µm 10-20 µm nanofibre coating 0.1-0.4 µm
Comments	F1 flame retardant (optional)	High capacity F1 flame retardant	High efficiency nanofiber coated medium F1 flame retardant	High efficiency, high capacity nanofiber coated medium F1 flame retardant

Different filter medias result in different filter performances and characteristics

Oil Filters



- **MULTIGRADE O-C: Standard cellulose-based media** for standard requirements
- **MULTIGRADE O-MG: Mixed fibre media (cellulose + glass)** with higher filtration efficiency, especially requested on US market
- **MULTIGRADE O-M: Long-life mixed fibre media (cellulose + polyester)** with increased chemical resistance for aggressive oils and extended service intervals
- **MULTIGRADE O-S: Fully synthetic media** for severe oil conditions and reduced installation space
- **MULTIGRADE O-G: highest efficiency combined with high capacity** Highly efficient through intelligent multi-layered designs

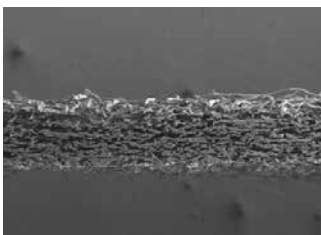

MULTIGRADE O-C
Cellulose

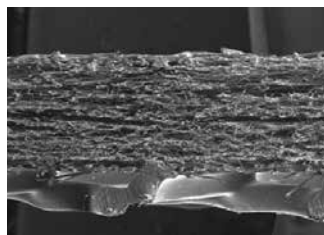

MULTIGRADE O-M
Cellulose with polyester fibres

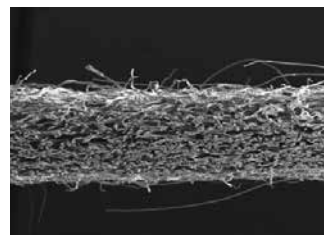

MULTIGRADE O-S
100 % polyester fibres

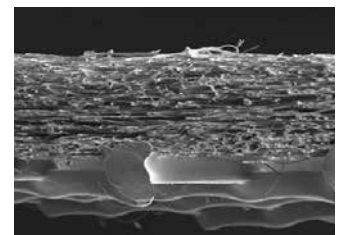

MULTIGRADE O-G
100 % glass fibres

Atlas Copco High Quality Media

- Strong and uniform filter media
- Optimum Quality and lifetime
- Absolutely impermeable, optimum Δp
- High resistance against humidity

Result

- No engine and element wear
- Long service lifetime
- Less fuel consumption

VS



Low Quality media

- Media tearing easily
- Gets clogged sooner
- Faster Δp Increase (fuel consumption)
- Absorption of water, changing quality

Result

- High engine and element wear
- Less service lifetime
- Increased fuel consumption

Atlas Copco High Stabilization

- Pleated bellows maintain shape under all operating conditions and allow for ideal air flow.
- Embossed filter media.
- Stabilized with glue beads, support inserts or pleat lock (compressor oil filter).
- Media impregnation to protect against ingress of moisture.

VS



Low Stabilization

- Embossment or stabilizing inserts are not adequate or missing.
- Media compresses and pleats stick together reducing filtration surface area causing lower capacity and possible tearing of media.
- Sharp metal edges destroy element and cause leakage.
- Inadequate or lack of impregnation allows media to absorb moisture and swell, causing wavy appearance and weak media.



Compressor Oil Filter Atlas Copco

Result

- The filter collapses prematurely
- Reduced lifetime for the machine
- Less service lifetime

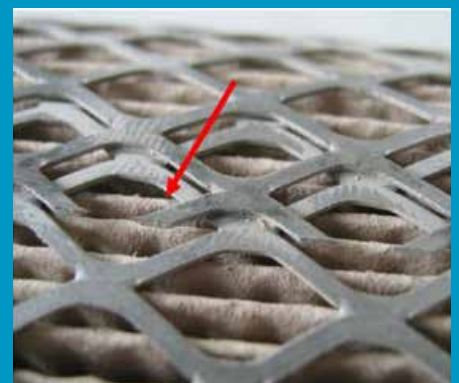

Compressor Oil Filter Competition

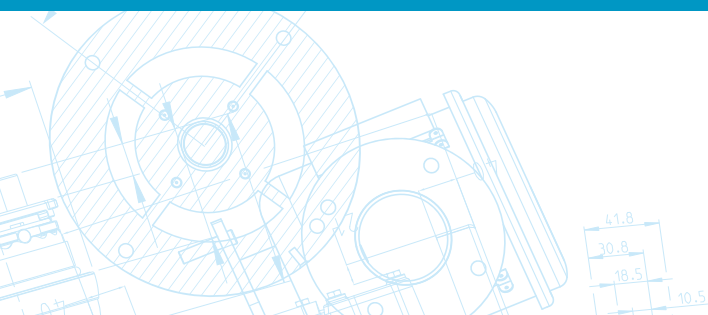

Sealing

Atlas Copco

- Seal provides air tight with housing.
- No bypass.
- Resistant within normal temperature ranges.
- Material retains elasticity throughout service life.

VS

Pirate Filters

- Low quality material.
- Too hard or too soft material does not seal.
- Material loses elasticity when exposed to engine or compressor vibrations.
- Seals may crack leading to bypass.
- Bellow ends may be overlapped without joint allowing continuous bypass.

Result

- High level of wear on all the components
- Reduced life time for the machine

Fire Protection



Atlas Copco Separator Filter



Pirate Separator Filter

We apply special water treatment to provide flame retardant air filters which reduces the risk of internal fires.



Atlas Copco Air Filter

Flame
retardancy
after water
treatment.



Pirate Air Filter

2. Invisible differences

Despite the same filter media, depth filtration behavior of filters can vary due to micro structural differences. The performance results can only be proven by conducting certain type of tests.

The biggest challenge here is to provide the most optimum filter for a certain application. Atlas Copco offers the best filter for our applications to reduce your cost of ownership.

There are three vital parameters for every filter which defines its characteristic behaviors and also the performance.

- 1. Filtration Efficiency**
The filtration effectiveness due to the quality of the filter media to separate dust out from the filtration system.
- 2. Dust Holding Capacity**
The capacity of the filter to hold dust, if the filter becomes too tense to increase the filtration efficiency, dust cake will build up faster and dust holding capacity will be reduced.
- 3. Restriction Level (Pressure difference)**
The pressure differences due to filtration process. If filtration efficiency increases too much, restriction level of the filter will also increase which will lead to high ΔP . As a result, fuel consumption will increase.

Filtration Efficiency

High Efficiency

- Ensure small particles are captured within the depth of the media.
- Air filter removes the dust and dirt from the ambient air.
- **Air Separation Efficiency**
99.9% for parts $> 3 \mu\text{m}$
99.5% for parts $> 1 \mu\text{m}$
- **Oil Separation Efficiency**
50% of $18 \mu\text{m}$ size particles
99% of $30 \mu\text{m}$ size particles

VS

Separation Efficiency

Poor Efficiency

- Coarse media allows fine particles to pass through or too fine media unnecessarily increases Δp which lead to high fuel consumption or to low dust holding capacity.
- **Separation Efficiency**
When comparing an extraction efficiency of 99.8% with 99.9% you will have two times more dust.

Result

A bad separation capacity (low extraction efficiency) means that more dust will enter the unit. At the same time the lifetime of the Compressor Oil, Oil Filter and Oil Separator is drastically reduced.

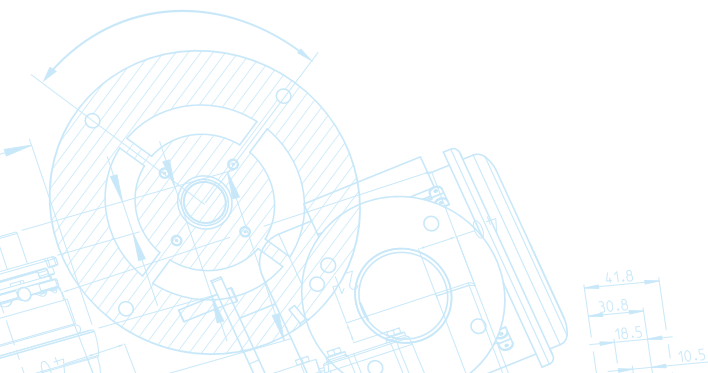

Depending on the environmental conditions the separation efficiency can be quite significant. When comparing the separation efficiency of 99.8% with 99.9% you will have two times more dust. This image illustrates the drastic impact in the amount of dust that can go into your machine based on the environmental conditions therefore a 0.1% difference in separation efficiency can double the amount of filtration.

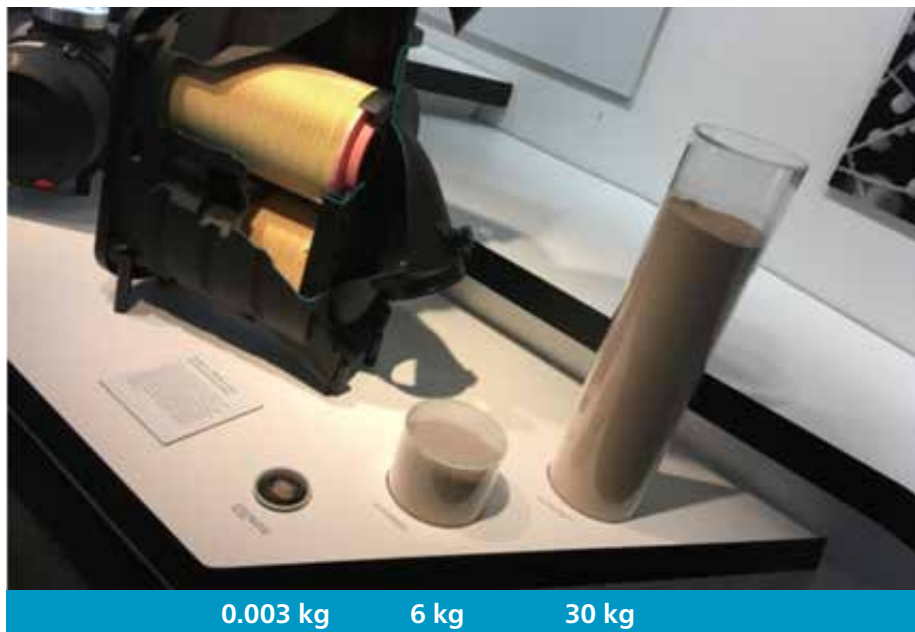

Nominal Flow Rate



High or Low flow rate

Flow rate Efficiency

The nominal flow rate of the filter (m^3/min) is decisive for the filter size. Original Part air filter ensures you the optimum filter for your unit, matched perfectly to its air consumption. The filter size is calculated in order to have the lowest flow resistance.

Result

A flow resistance of 25 mbar at the air inlet will reduce the compressor output with 2%. This will also lead to increased fuel consumption.

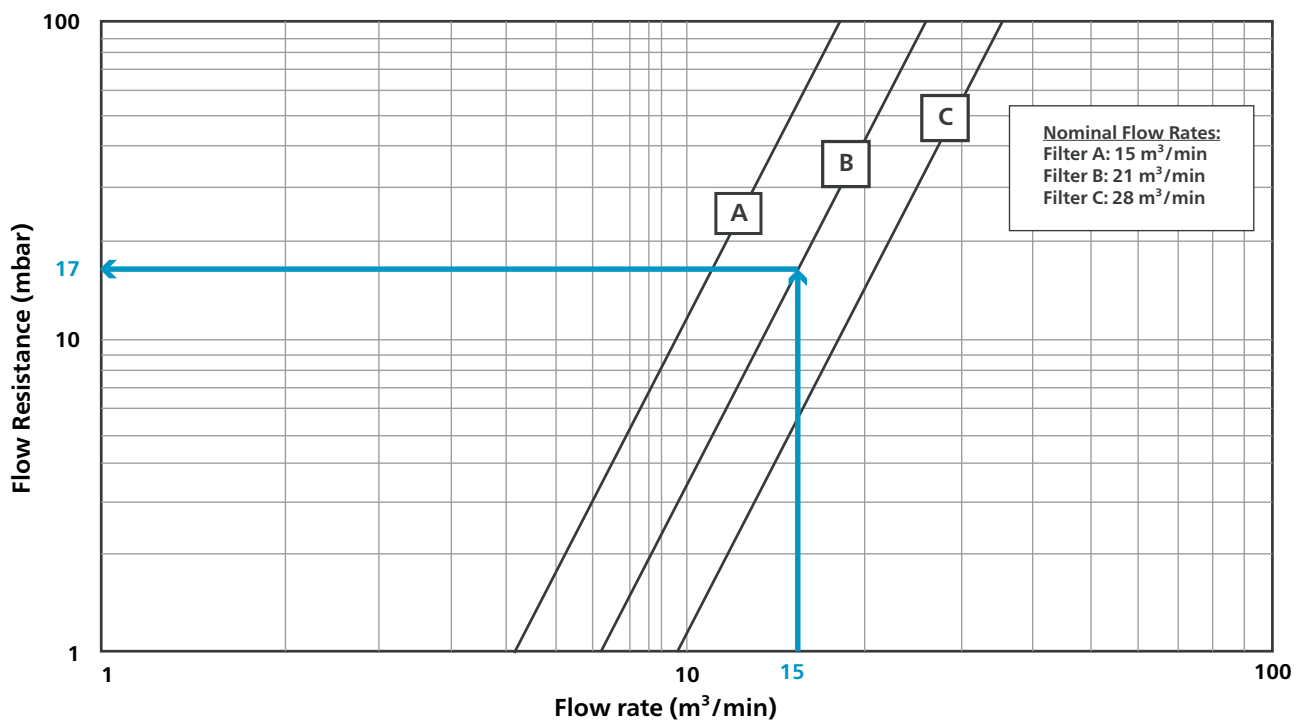

Dust Holding Capacity (DHC)

High Dust Holding Capacity

VS

Low Dust Holding Capacity

(Air and Liquid Filters)

The flow resistance Δp is measured in mbar, and depends on the volume flow. The dust settles on the filter medium and gradually increases the flow resistance.

Result

If more dust is accumulated on your filter;

- Δp of your filter element increases, and you will have less air intake. A too high Δp can result in engine damage or impermissible and increase fuel consumption environmental pollution (smoke limit in diesel engines).
- The FAD (Free Air Delivery) will decrease. So you will have less air at your outlet valves.
- The pressure ratio over the element increases, resulting in premature element wear.

Due to an increasing flow resistance Δp of the filter, the pressure ratio over the element can increase very fast, resulting in premature element wear. (Extra load on compressor bearings, vibrating of male rotor against female rotor, seals might get damaged)

Example

- Filter with a Δp of 20 mbar: Pressure ratio = $(7+1)/(1-0.020) = 8.16$
- Filter with a Δp of 100 mbar: Pressure ratio = $(7+1)/(1-0.1) = 8.8$

Restriction Limits

Low Restriction Limits

VS

High Restriction Limits

The pressure differences due to filtration process. If filtration efficiency increases too much, restriction level of the filter will also increase which will lead to high ΔP . As a result fuel consumption will increase.

For compressor oil filters we have a bypass valve in the filters that will open ensuring sufficient lubrication still when a certain differential pressure is reached.

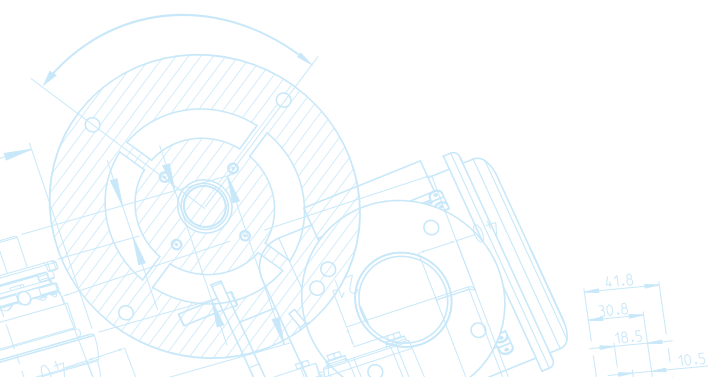

Bypass Valve Oil Filter

The compressor oil absorbs the heat generated by compressing the air. If a clogged filter would disturb the oil flow, the temperature of the rotors and rotor housing would rise instantly and result in a catastrophic failure of the compressor element.

It is less harmful to supply unfiltered oil to the element than to supply no oil at all.

Bypass Valve Function

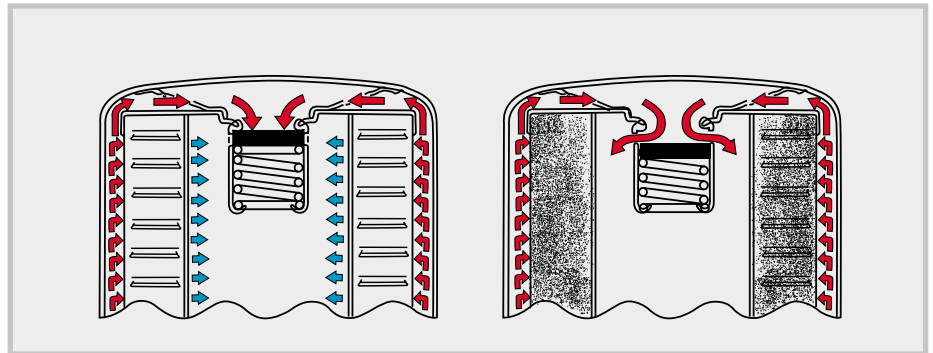

A bypass valve in the filter will open ensuring sufficient lubrication when a certain differential pressure is reached (e.g. upon cold start or when the filter element is clogged). If you start the unit and the oil is still cold, (high viscosity) this will create a pressure drop and the bypass valve opens. At this moment unfiltered oil will pass temporary to the element. It is important that this valve opens at the correct pressure, if it opens too soon, which can happen in pirate filters, a high quantity of unfiltered oil will have passed to the elements, increasing the risk of premature wear.

There are a few possible scenarios

1 Bypass valve is not present

Result: Insufficient oil flow to the element when the filter gets clogged. The temperature of the compressor element (and compressor oil) will rise instantly and result in a catastrophic failure of the compressor element.

2 Bypass valve is installed but the opening pressure is too low

Result: Unfiltered oil will flow to the compressor bearings, resulting in premature wear of the bearings.



Genuine Filters

Features

Air Filter



- Air filter sealing
- Uniquely designed filtration paper with special indentations traps foreign materials without impeding incoming air flow, maximizing efficiency
- Traps particles down to 3 microns, preventing 99.9% of contaminants from reaching compressor element

Oil Filter



- Bypass valve guarantees continuous oil flow to compressor element in cold-start conditions or in the event of a clogged filter
- High-performance, finely textured, temperature- and synthetic-compressor-oil-resistant filter paper
- Corrosion-resistant material that maximizes compressor oil lifetime
- High dirt-holding capacity to extend service intervals while protecting compressor element
- Uniform paper pleat spacing for most effective filtering area and increased mechanical resistance to pressure fluctuations.
- Withstands high operating pressures, increasing safety

Air/oil separator



- Outstanding separation efficiency for low oil consumption and high-quality compressed air
- Electrically interconnected metallic parts to prevent electrostatic discharges and reduce the risk of internal fires
- High mechanical strength for longer lifetime
- Corrosion-resistant material to minimize oil degradation
- Low pressure drop reduces fuel consumption

Fuel Filter



- High dirt-holding capacity to protect fuel system
- Water separation for optimum engine power output
- Corrosion-resistant material for longer lifetime
- Special rubber seals to prevent fuel leaks
- Elastic-bonded joints to prevent leaks caused by vibrations and pressure
- Highly durable paper pleats for effective filtering area and mechanical resistance to pressure fluctuations

All Filters

- Best optimization on the most important parameters for compressor applications
 - Dust holding capacity
 - Separation efficiency
 - Restriction



Benefits

- Separation efficiency > 99.9% protects compression element
- Increases lifetimes of oil, oil filter and air/oil separator
- Minimum pressure drop for optimum compressor output
- High-quality filter and seals guarantee 100% air filtration
- High humidity resistance even in demanding environments

- High operational reliability
- Decreased energy and oil consumption
- Longer service life

- Guarantees residual oil content as low as 1-3 ppm at a differential pressure of 0.2 bar in the compressed air delivered by the compressor
- Reduced oil consumption and longer lifetime of filters minimize operating costs
- Reduced risk of internal fires

- Longer injector lifetime
- High engine power output
- Lower service costs

- Increased life time for filters and all components
- Reduced cost of ownership
- Maximized compressor efficiency

Disadvantages of non-genuine parts

- Additional pressure drop of 25mbar for 2% lower compressed air output
- Reduced oil, oil filter and air/oil separator lifetimes
- Higher service costs
- Increased fuel consumption
- Risk of compression element damage

- Lower separation efficiency
- Low adhesive quality results in cracks in paper pleats and non-filtered oil
- No bypass valve
- Paper pleats are not uniformly spaced, reducing the filtration area and filtration efficiency
- No protection against corrosion
- Risk of compression element damage

- Increased oil consumption
- Higher service costs
- Increased fuel consumption
- Risk of internal fires

- Larger dirt particles in the fuel
- No water separation
- No corrosion-resistant material
- Inadequate sealing and risk of fuel leaks
- Shorter service life – up to 50%

Test Results

Micro structural differences which leads to performance can only be measured by different types of tests. Depending on the type of the filters, the priority level of above parameters will vary.

In order to prove, we have the best optimized filters for our applications, we also would like to share some of our test results with you conducted by independent laboratories for particular filters.

Air Filter Test Results

Property	Competitor 1	Competitor 2	Competitor 3	Atlas Copco	Effect
Restriction of the filter system (mbar)	17.1	20	16.9	15.6	Influences energy consumption & efficiency
Separation Efficiency 40mbar increase (%)	99.93	99.78	99.92	99.93	Influences energy consumption & efficiency, service interval of air oil separator
Dust holding Capacity (g)	1396	370	1812	1903	Influences energy consumption & efficiency, service interval of air cleaner

Note: Filtration performance measured according to ISO 5011.

Competitor 1

- Initial restriction: 1.5 mbar higher compared to Atlas Copco.
- Dust Holding Capacity: - %27 lower compared to Atlas Copco.

Competitor 2

- Initial Restriction: 4.4 mbar higher compared to Atlas Copco.
- Dust Holding Capacity: - 80% lower compared to Atlas Copco (based on less pleat stabilization->pleats collapse).
- Total Filtration Efficiency: 3 times more dust pass the element compared to Atlas Copco.

Competitor 3

- Initial Restriction: 1.7mbar higher compared to Atlas Copco.
- Dust Holding Capacity: Less than Atlas Copco.

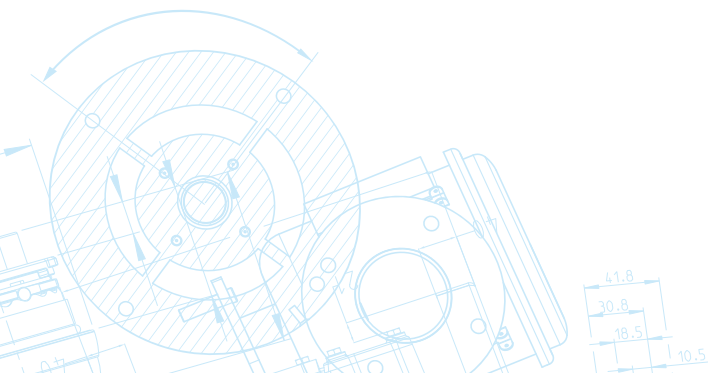

Oil Filter Test Results

Property	Competitor 1	Competitor 2	Atlas Copco	Effect
By-pass Valve Opening Pressure	Opens too early	Opens early	On time	Influences energy consumption & efficiency
Filter Media	Cellulose + synthetic fiber	Cellulose + synthetic fiber	Cellulose + PET+synthetic fiber	
Separation Efficiency %99 particule size 3 µm	39.1	>50	25	Influences energy consumption & efficiency
Service interval of air oil separator	1396	370	1903	Influences energy consumption & efficiency, service interval of air cleaner
Dust holding Capacity (g)	53.3	65.7	54.5	Influences energy consumption & efficiency

Competitor 1

By-pass valve opens too early, a high quantity of unfiltered oil will have passed to the elements, increasing the risk of premature wear.

Competitor 2

- Good dust holding capacity, however very low separation efficiency which will lead to reduced life time for parts and filters.
- By-pass valve opens too early.

Given the test results, it is proven that Atlas Copco filters are tailor made filtration solutions for portable compressor applications providing the best performance for your machine and also increased lifetime with the best optimization of filtration parameters.



