



Atlas Copco



Atlas Copco



# High Pressure air-cooled compressors

ZP Series (170-835 m<sup>3</sup>/h, 110-490 cfm)

# Boost your productivity

---

As a leader in compressed air technology, we have always created the benchmark in innovation. Keeping in mind the comfort of your operators, our new innovative air-cooled series come equipped with a silent and compact canopy as a plug and play solution. The groundbreaking rod drop monitoring technology sets a new standard in piston technology. This is a whole new way to reduce your operational costs and increase up-time.



## Choose ZP – our air-cooled solution

Thanks to the new ZP air-cooled compressor, you can achieve immediate and long-term savings in investment, maintenance, water treatment and water consumption. The ZP needs no external cooling circuit, this means no cooling tower or cooling unit, no water pump skid and no piping. This immediately and significantly slashes the investment and maintenance costs.

## All-in-one solution

Atlas Copco does not just offer the most reliable and efficient compressors, we can also help you get the most cost-efficient solution throughout your entire process. We designed a range of class-leading compressed and air products, fully optimized to work better together. Our smart AIR solution includes dryers, filters, air receivers and controllers.

## Protecting your production and reputation

An accidental contamination increases the risk of production down time and may lead to expensive cleaning of your process. With Oil-free technology, you avoid pressure losses due to less piping and filters in the air network, this also leads to immediate savings. It's not only your production that's at stake, but also your reputation. By providing high-purity clean air, the ZP protects your company's reputation in the marketplace, ensure safety and help protect the environment.

## Quiet by design and compact

The ZP is silent, easy to manage and service, making it greatly appreciated by your operators.





# Serving the PET industry with our new innovative air-cooled solution

---

Compressed air is a vital resource in your PET blow molding operation. An interruption in the air supply leads to a loss of product, expensive delays and costly restarts. The smallest contamination from unwanted particles can corrupt your product quality and affect the performance of products.







## Your PET business partner

You don't want to worry about air. It just has to be there, around the clock, in the right flow, pressure and quality. You want to concentrate on your business, and more importantly, on a sound bottom line. As a leader in compressed air technology, Atlas Copco compressors understand your needs and has put its experience of more than a century to work for your profitability. A professional service organization across the globe will ensure your optimum productivity and reliability of machines round the clock.

### Your benefits:



**Reliability**



**Energy efficiency**



**Air quality**



**Lowest cost of ownership**



**Local support**



**Increased productivity**

# Silent, compact plug and play solution

---



# ZP 55

RIGHT VIEW

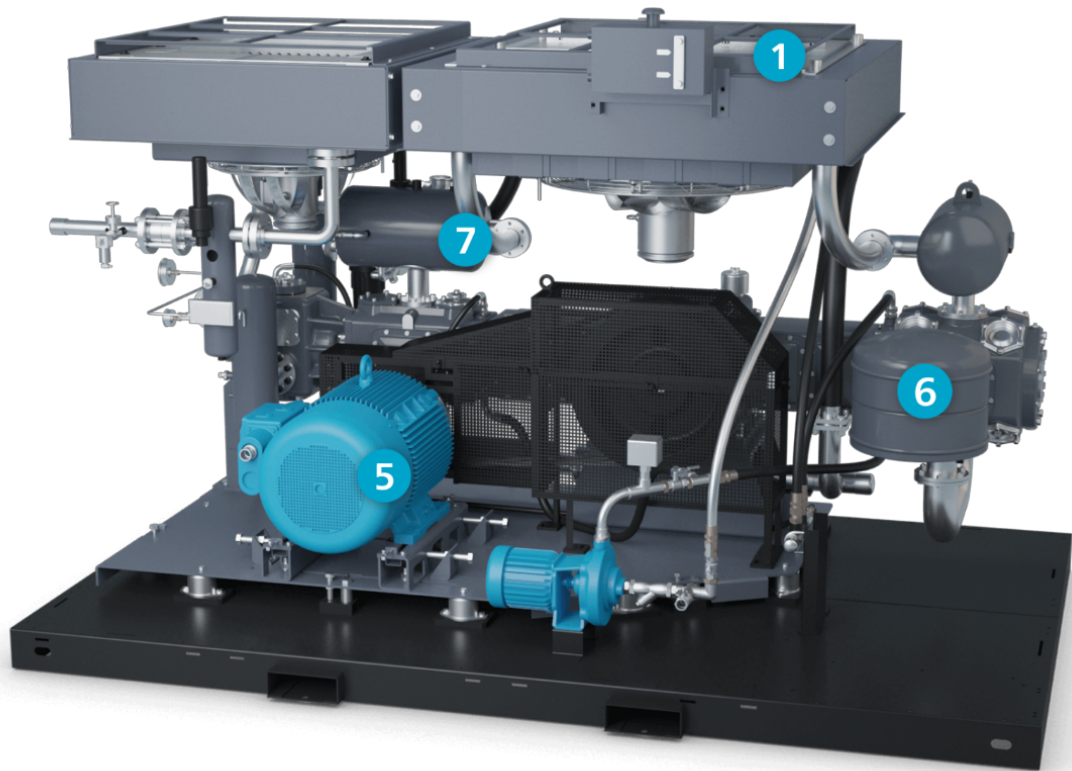

LEFT VIEW

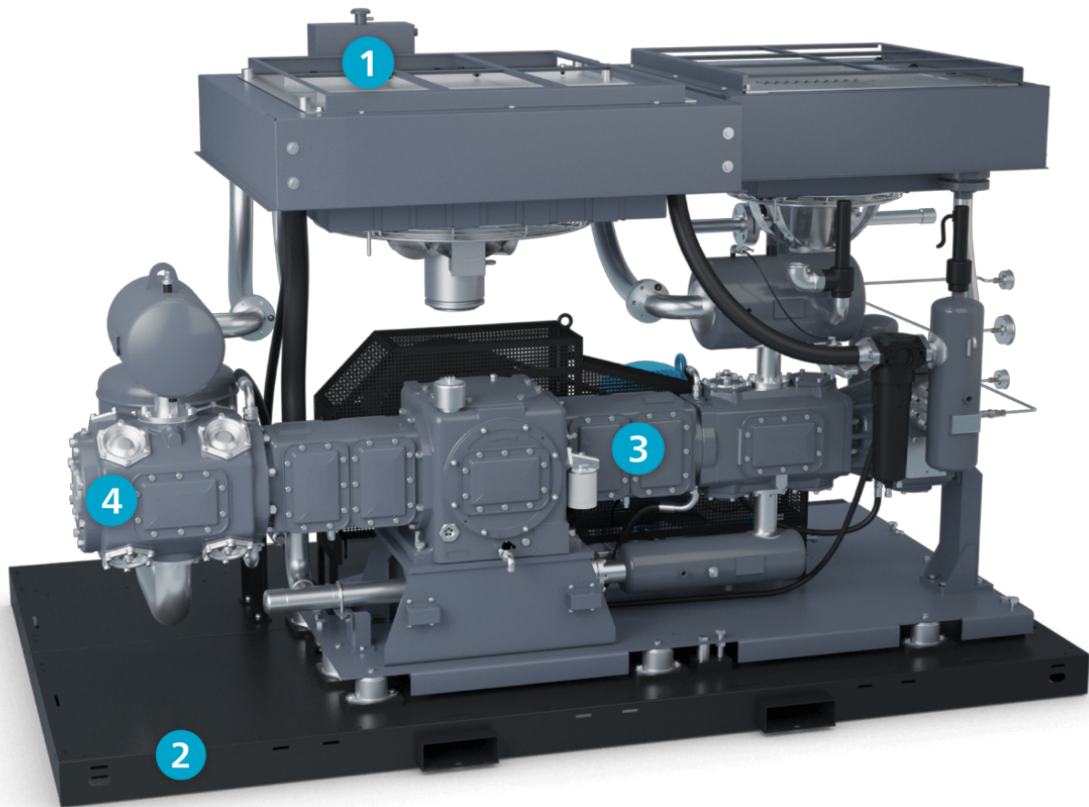



## 1 Unique cooler assembly

The only manufacturer using air cooled technology suitable for 50°C ambient environment. These coolers eliminate the need to install accessories such as cooling water tower, cooling water pump, make up water and interconnecting piping. Fast installation, low floor space, no maintenance for accessories.

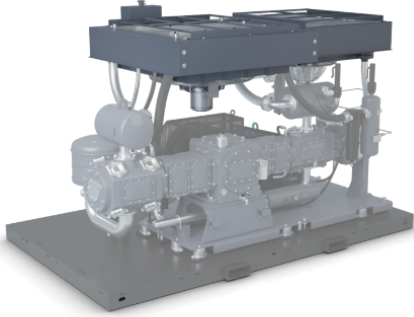

## 4 Oil-free air piston technology

- Completely oil-free chambers with PTFE piston rings & long distance pieces with wiper rings.
- No risk of contamination, damaged products or losses from operational downtime.
- Reduced maintenance costs as there is no need for oil filtration.

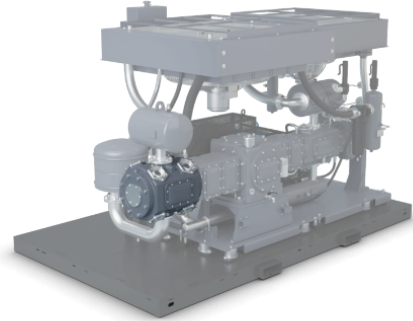

## 2 Plug and play solution

Horizontal BOP design and dynamically balanced arrangements leads to lesser vibration levels. This machine comes with unique base frame design & special elastomer anti-vibration mounts, needing no special foundation.

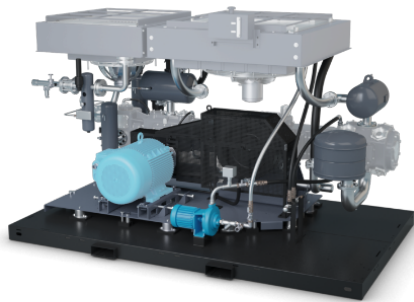

## 5 Efficient drive system with IE3 motors

The standard machine comes fitted with the premium efficiency IE3 TEFC motor, suitable to operate at 50 °C ambient condition. These continuous duty motors run at low speeds, designed for longer life. Intelligent 3 part belt guard design ensures easy assembly and maintenance.

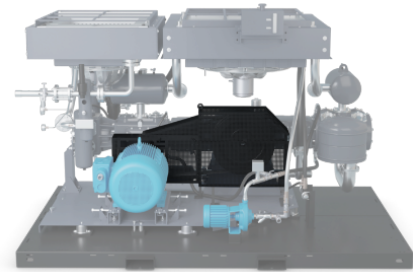

## 3 Setting a new standard with the rod drop technology

The only manufacturer to integrate sensors to optimize the availability of the machine, leading to increased reliability and lower maintenance costs.

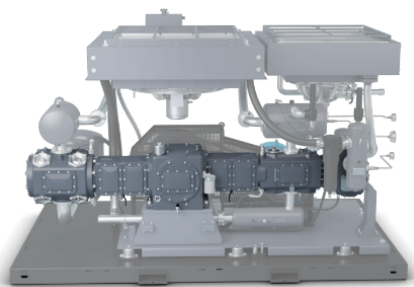

## 6 Advanced monitoring system

- User-friendly Elektronikon<sup>®</sup> with enhanced connectivity potential.
- Integrated smart algorithms to optimize system pressure and maximize energy efficiency.
- Included warning indications, maintenance scheduling and online visualization of the machine's condition.



## 7 Low noise level

The closed canopy drastically reduces the noise level compared to piston compressors which increases the working comfort.



# ZP 132

## RIGHT VIEW

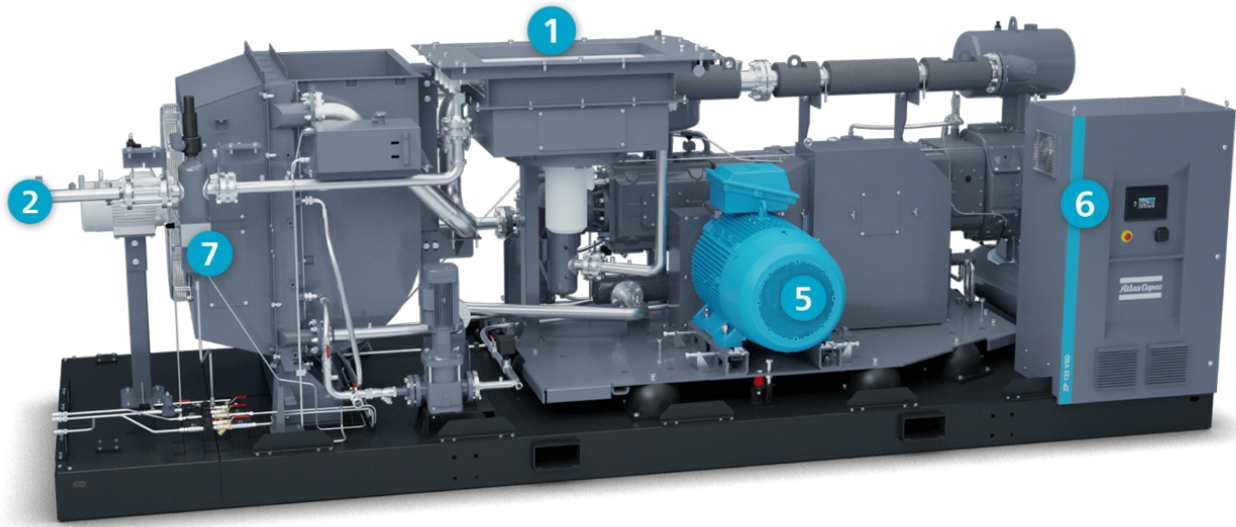

## LEFT VIEW

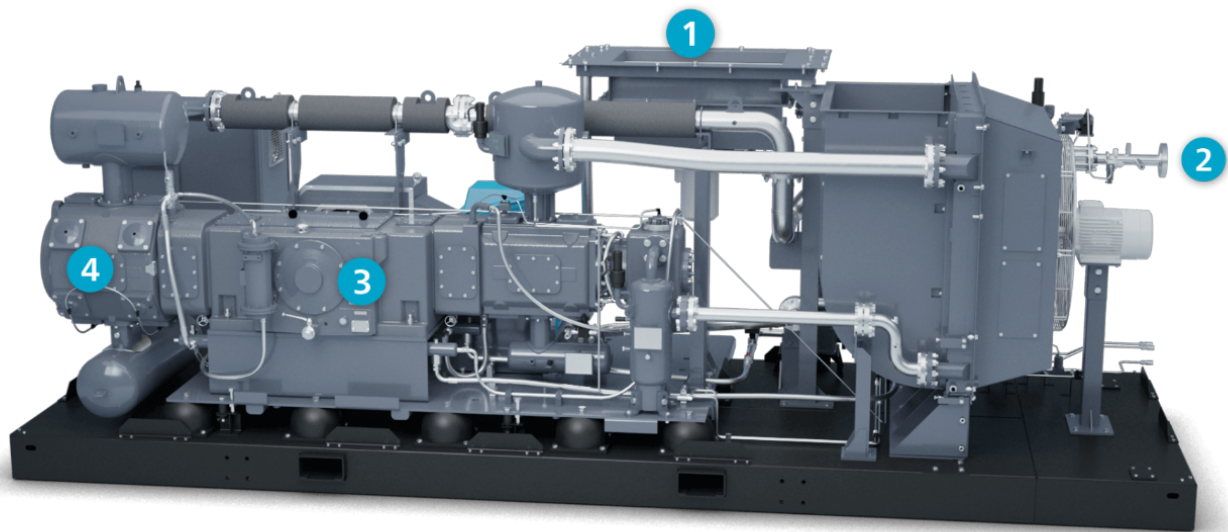



## 1 Unique cooler assembly

The only manufacturer using air cooled technology suitable for 50°C ambient environment. These coolers eliminate the need to install accessories such as cooling water tower, cooling water pump, make up water and interconnecting piping. Fast installation, low floor space, no maintenance for accessories.



## 4 Oil-free air piston technology

- Completely oil-free chambers with PTFE piston rings & long distance pieces with wiper rings.
- No risk of contamination, damaged products or losses from operational downtime.
- Reduced maintenance costs as there is no need for oil filtration.

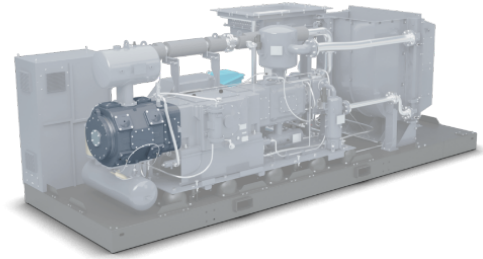

## 2 Plug and play solution

Horizontal BOP design and dynamically balanced arrangements leads to lesser vibration levels. This machine comes with unique base frame design & special elastomer anti-vibration mounts, needing no special foundation.

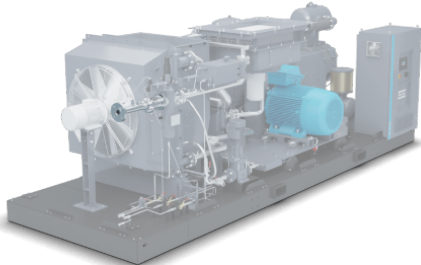

## 5 Efficient drive system with IE3 motors

The standard machine comes fitted with the premium efficiency IE3 TEFC motor, suitable to operate at 50 °C ambient condition. These continuous duty motors run at low speeds, designed for longer life. Intelligent 3 part belt guard design ensures easy assembly and maintenance.

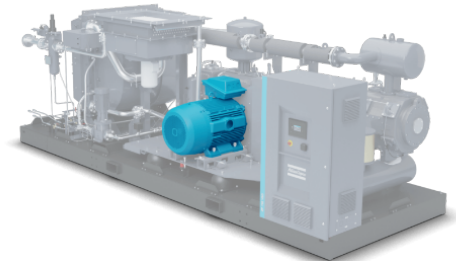

## 3 Setting a new standard with the rod drop technology

The only manufacturer to integrate sensors to optimize the availability of the machine, leading to increase reliability and lower maintenance costs.

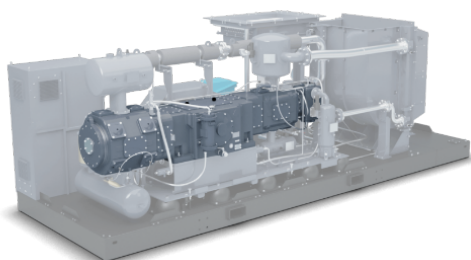

## 6 Advanced monitoring system

- User-friendly Elektronikon<sup>®</sup> with enhanced connectivity potential.
- Integrated smart algorithms to optimize system pressure and maximize energy efficiency.
- Included warning indications, maintenance scheduling and online visualization of the machine's condition.



## 7 Low noise level

The closed canopy drastically reduces the noise level compared to piston compressors which increases the working comfort.



# ZP 132 FF

FRONT VIEW



BACK VIEW





## 1 Cooler

## 2 Plug & play

## 3 New technology

## 4 OFA piston

## 5 Drive

## 6 Monitoring

## 7 Low noise

## 8 FF = Full Feature

All the sizes of ZP can be executed in Full Feature (FF) version to deliver dried and filtered high pressure air.  
For easy assembly, the FF-part comes with all pipes and electrical connections included, this to maintain the Plug&Play concept.  
For easy transport, installation and still maintain flexibility, the FF part comes on it's own skid, which can be installed straight after the ZP or under a 90° angle.



## 9 FDH dryer

On the FF part, there is a fully inhouse build and designed High Pressure refrigerant dryer, called FDH  
Thanks to the stainless Steel Heat exchangers, including and Air-Air part and Air-refrigerant part, the final outlet air achieves dewpoints down to 3° C and a Relative Humidity below 50%  
With the selected refrigerant, the FDH dryer is able to be used to higher ambient temperatures, even up to 50° C



## 10 HP vessel

Removing pulsations and improving regulation performance are the 2 reasons on why a vessel is a must have on any piston compressor, which in case of the FF-version, this is included in the scope  
Vessel is suitable for high pressure and adequately sized for the functions. Additionally, it comes with drain at the bottom to remove condensation that is not taken out already



# Refrigerant dryers for superior productivity

---



## Low noise

Specially designed cooling fan to ensure low running noise. Unique rotary compressor assembly with integrated liquid separator leads to limited vibrations, minimal moving parts not only ensures silent operation but also reduces the risk of leakage.

## Reliability

Use of hot gas bypass ensures stable pressure dew point and eliminates the possibility of condensate freezing. Our refrigerant dryers come equipped with reliable stainless steel heat exchangers. Reliable water separators further leads to a stable dew point.

## Easy maintenance

Although our refrigerant dryers are built with a compact small footprint, easy access to key components allows for fast and smooth maintenance.

## Digital display

Provides peace of mind through precise monitoring and display of pressure dew point.



# VSD: driving down energy costs

---

Over 80% of a compressor's lifecycle cost is taken up by the energy it consumes.

Moreover, the generation of compressed air can account for more than 40% of a plant's total electricity bill. To cut your energy costs, Atlas Copco pioneered Variable Speed Drive (VSD) technology in the compressed air industry.







## Energy savings up to 35%

Atlas Copco's Variable Speed Drive technology leads to major energy savings, while protecting the environment for future generations. Thanks to continual investments in this technology, Atlas Copco offers the widest range of integrated VSD compressors on the market.

Atlas Copco's VSD technology closely follows the air demand by automatically adjusting the motor speed. This results in large energy savings of up to 35%. The Life Cycle Cost of a compressor can be cut by an average of 22%. In addition, lowered system pressure with VSD minimizes energy use across your production dramatically.

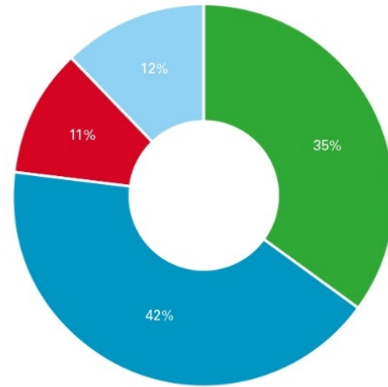

**Total compressor lifecycle cost**

- Energy
- Investment
- Energy savings with VSD
- Maintenance

## What is unique about the integrated Atlas Copco VSD?

- The Elektronikon® controls both the compressor and the integrated converter, ensuring maximum machine safety within parameters.
- Flexible pressure selection with VSD reduces electricity costs.
- Specific converter and motor design (with protected bearings) for the highest efficiency across the speed range.
- Electric motor specifically designed for low operating speeds with clear attention to motor cooling and compressor cooling requirements.
- Mechanical enhancements ensure that all components operate below critical vibration levels throughout the entire compressor speed range.
- A highly efficient frequency converter in a cubicle ensures stable operation in high ambient temperatures up to 50°C/122°F (standard up to 40°C/104°F).
- Net pressure band is maintained within 0.10 bar, 1.5 psi.

# Neos: our in-house integrated inverter

---



## Dedicated compressor drive

Atlas Copco pioneered the first VSD compressors. We learned from field experience that traditional drives suffer in compressor applications from dust, humidity, over currents, etc. It was time to put all this expertise together and develop a drive tailor-made to Atlas Copco's compressors.

## Simplicity is key

Neos has been designed in-house by Atlas Copco. The focus is on compactness, simplicity and user-friendliness.

## Designed for robustness

Neos has an IP5X protection degree. All components in the drive are protected from dust and moisture, thanks to a robust, aluminum enclosure. The Neos will operate trouble-free in the harshest conditions.

## Eco-friendly design

Less components, also means the Neos has less impact on the environment at the end of its lifecycle. For us, long-term sustainability is a crucial part of innovation.



# Monitoring and control: get the most from the least

The Elektronikon<sup>®</sup> unit controller is specially designed to maximize the performance of your compressors and air treatment equipment under a variety of conditions. Our solutions provide you with key benefits such as increased energy efficiency, lower energy consumption, reduced maintenance times and less stress... less stress for both you and your entire air system.



## Intelligence is part of the package

High resolution color display gives you an easy to understand readout of the equipment's running conditions.

- Clear icons and intuitive navigation provides you fast access to all of the important settings and data.
- Monitoring of the equipment running conditions and maintenance status; bringing this information to your attention when needed.
- Operation of the equipment to deliver specifically and reliably to your compressed air needs.
- Built in remote control and notifications functions provided as standard, including simple to use Ethernet based communication.
- Support for 31 different languages, including character based languages.

## Online monitoring

Monitor your compressors over the Ethernet with the Elektronikon<sup>®</sup> unit controller. Monitoring features include warning indications, compressor shut-down and maintenance scheduling. An Atlas Copco App is available for iPhone/Android phones as well as iPad and Android tablets. It allows fingertip monitoring of your compressed air system through your own secured network.

## Dual pressure set-point

Most production processes create fluctuating levels of demand which, in turn, can create energy waste in low use periods. Using the graphic Elektronikon<sup>®</sup> unit controller, you can manually or automatically create two different system pressure bands to optimize energy use and reduce costs at low use times.

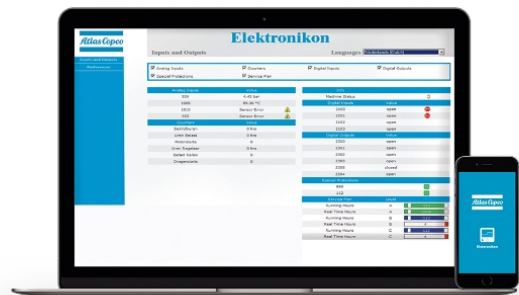



## SMARTLINK

### Monitor your compressed air installation

Knowing the status of your compressed air equipment at all times is the surest way to achieve optimal efficiency and maximum availability.

### Go for energy efficiency

Customized reports on the energy efficiency of your compressor room.

### Increase uptime

All components are replaced on time, ensuring maximum uptime.

### Save money

Early warnings avoid breakdowns and production loss.

## Evolving towards compressed air management

### SMARTLINK Service

A mouse-click reveals the online service log. Get quotes for parts and additional service quickly and easily.

### SMARTLINK Uptime

Uptime additionally sends you an e-mail or text message whenever a warning requires your attention.

### SMARTLINK Energy

Energy gives you customized reports on the energy efficiency of your compressor room, in compliance with ISO 50001.





# Technical specifications

## ZP 55-110-132 (FS/VSD)

Model	Working pressure		Capacity (1)				Motor power		Dimensions L x W x H (mm)		
	bar(e)	psig	l/s	m <sup>3</sup> /h	cfm	Nm <sup>3</sup> /h	kW	HP	ZP	FF Skid	
ZP 55	40	580	86	310	182	285	55	75	3621 x 2110 x 2190	2000x1650x2100	
ZP 55 VSD											
ZP 110			191	692	406	632	110	150	6296 x 2218 x 2196	2335x2100x2100	
ZP 110 VSD											
ZP 132			231	837	492	766	132	180			
ZP 132 VSD											

(1) Reference conditions:  
 Absolute inlet pressure: 1 bar (14.5 psi)  
 Intake air temperature: 20°C (68°F)



[WWW.ATLASCOPCO.COM](http://WWW.ATLASCOPCO.COM)

**Atlas Copco AB**  
(publ) SE-105 23 Stockholm, Sweden  
Phone: +46 8 743 80 00  
Reg. no: 556014-2720

