

Atlas Copco

# Oil-free scroll compressors

SF+ 1-6 (1.5-5.5 kW/2-7.5 hp)

SF+ 8-22 (7.4-22 kW/10-30 hp)





## Innovating for a sustainable future

At Atlas Copco, we have always looked ahead. Which products and services will make our customers more successful? Your future drives the Atlas Copco team every day. It is the reason why we devote so much time and so many resources to innovation. If there are technologies that will advance your productivity, we will find them. That is what we have been doing for more than 150 years now, setting new standards in compressed air reliability, efficiency, connectivity, and sustainability.

It's that last principle that now comes first. Sustainability is no longer something we should strive for, but something we must achieve. Productivity and growth will have to be built on sustainability. Atlas Copco – our products, our services, and our people – will help you get there, as we always have.

### The technology that drives energy efficiency



#### Class 0 clean air

Atlas Copco's oil-free scroll compression technology eliminates the risks of working with oil lubrication, including disposal.

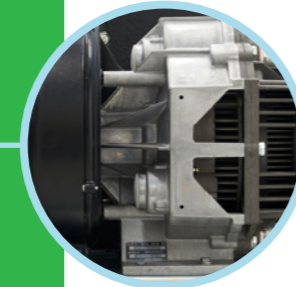

#### Low-noise scroll compressor

The SF+'s scroll element and IE3 motors give you premium efficiency and energy savings.



#### Elektronikon® controller

The state-of-the-art Elektronikon Touch offers control and remote monitoring features, including VFT technology, that allow you to increase your compressor's efficiency.

## Cost-efficient, high-quality air



Clean compressed air is a prerequisite for many manufacturing processes. Atlas Copco oil-free compressors prevent oil from entering your compressed air system. The SF+ scroll compressor series combines Atlas Copco's vast experience and knowledge in an industry-leading package. Reliable, quiet and compact, it meets your demands with innovative technologies and supreme energy efficiency.



#### SF+ 1-6 Efficient, silent & compact

- High-quality, oil-free air.
- IE3 Premium Efficiency motors.
- Extremely quiet: sound levels from 52 dB(a).
- SMARTLINK real-time, remote monitoring and optimization.



#### SF+ 8-22 Modular & flexible

- High-quality, oil-free air.
- IE3 Premium Efficiency motors.
- Modular with 2 to 4 compressor modules.
- Extremely quiet: sound levels of 63-65 dB(a).
- SMARTLINK real-time, remote monitoring and optimization.



# SF+ 1-6

## Efficient, silent & compact

The SF+ 1-6 is a complete package that includes an element, drive motor and aftercooler in a super-silent acoustic enclosure that can be installed directly onto your work floor. It is also available as a Full Feature unit with integrated refrigerant air dryer. Three receiver mounting options are available: with an extended canopy that includes three integrated 10-liter galvanized air receivers or mounted on an internally-coated 270-liter (72-gallon) or 500-liter (132-gallon) horizontal receiver.

### 1 Air inlet filter

High-efficiency paper cartridge air inlet filter eliminates dust and particles down to 1 µm.



### 2 Elektronikon Touch controller

- High-tech controller with warning indications, compressor shutdown and maintenance scheduling.
- Easy to use and designed to perform in the toughest conditions.
- Standard SMARTLINK remote monitoring to maximize air system performance and energy savings.

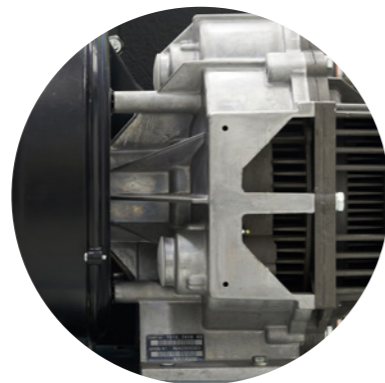

### 3 High-efficiency scroll element

Air-cooled scroll compressor element offers proven durability and reliability in operation, in addition to solid efficiency.

### 4 IP55 Class F/IE3 motor

Totally enclosed air-cooled IP55 Class F motors comply with IE3 Premium Efficiency standards.

### 5 Built-in dryer

Compact and optimized integrated refrigerant dryer ensures air quality and prevents rust and corrosion in your compressed air network.

### 6 Silent canopy

A sound-insulated canopy makes noise levels as low as 52 dB(A) possible, allowing you to install the unit closer to the point of use.

### 7 Integrated receiver

Plug-and-play solution, lower installation costs with 30l, 270l and 500l tank-mounted options.

### 8 Innovative design

The new compact vertical setup enables easy access for maintenance, improves cooling to allow for lower working temperatures, and provides vibration damping.

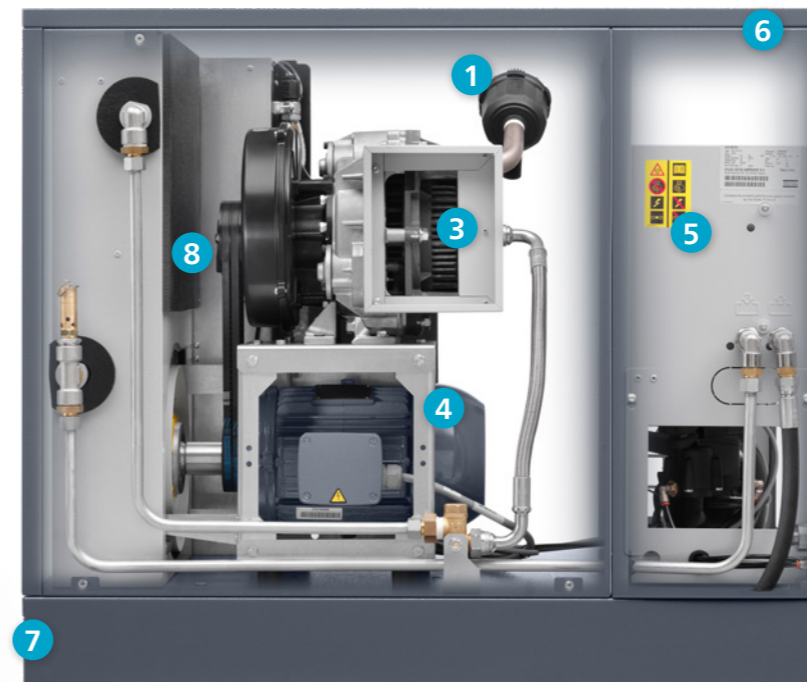

### 9 Cooler & piping

- An oversized cooler improves the performance of the unit.
- The use of stainless steel pipes and the vertically oversized check valve improve reliability and assure the quality of your compressed air.



### SF -Skid/Twin

- Suitable for installation at the point of use or for integration into an existing air network: designed with simplicity in mind.
- Self-contained units equipped with a single scroll element, drive motor, aftercooler and integrated starter, all contained in a modern silenced acoustic canopy.

# SF+ 8-22 Modular & flexible

SF+ 8-22 multi-scroll units bring the benefits and flexibility of a modular system, utilizing two to four compressor modules integrated into one canopy. The Elektronikon Touch controller continuously monitors the status of each element and starts and stops them to ensure that the output matches the air demand. Moreover, the perfect air quality and user-friendliness of these units guarantee a superior production process.



## 1 Air inlet filter

High-efficiency paper cartridge air inlet filter eliminates dust and particles down to 1 µm.

## 2 IP55 Class F IE3 motor

Totally enclosed and air-cooled IP55 Class F motors comply with IE3 Premium Efficiency standards.



## 3 High-efficiency scroll element

Air-cooled scroll compressor element offers proven durability and reliability in operation, in addition to solid efficiency.

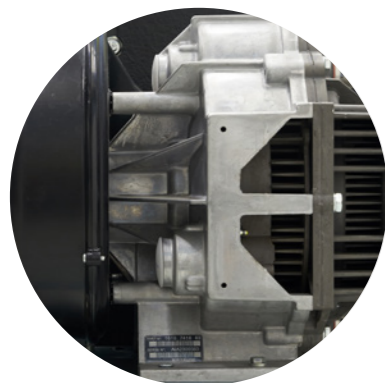

## 4 Integrated dryer

Compact integrated refrigerant dryer ensures air quality and prevents rust and corrosion in your compressed air network.

## 5 Silent canopy

Thanks to the low-noise scroll element, optimized super-silent fan and sound-insulated canopy, best-in-class noise levels can be achieved.

## 6 Elektronikon controller

- High-tech controller with warning indications, compressor shutdown and maintenance scheduling.
- Easy to use and designed to perform in the toughest conditions.
- Standard **SMARTLINK** remote monitoring to maximize air system performance and energy savings.

## 7 Optimized cooler & piping

The air cooler is finetuned for improved performance, while the aluminum and stainless steel pipes improve reliability and assure the quality of compressed air.

## 8 Smart design

Outstanding user-friendly design with safe operation and easy service.



## SF+ Duplex

- Duplex set-up with two cubicles, one/two main modules and one/two modules as back-up.
- Elektronikon controller regulates each set of compressor modules via an integrated central control system.
- Enclosed in sound-insulated bodywork.



# Advanced scroll technology

Air compression is achieved by the interaction of a fixed and orbiting scroll. Air at inlet pressure enters the compression chamber at the exterior side of the scroll element. Once air is drawn in, the orbiting scroll seals off the inlet port. As the scroll continues to orbit, the air is progressively compressed into an increasingly smaller 'pocket'. A continuous flow of compressed air leaves the scroll element through a discharge port in the center of the fixed scroll. This process is continuously repeated, resulting in the delivery of pulse-free compressed air.

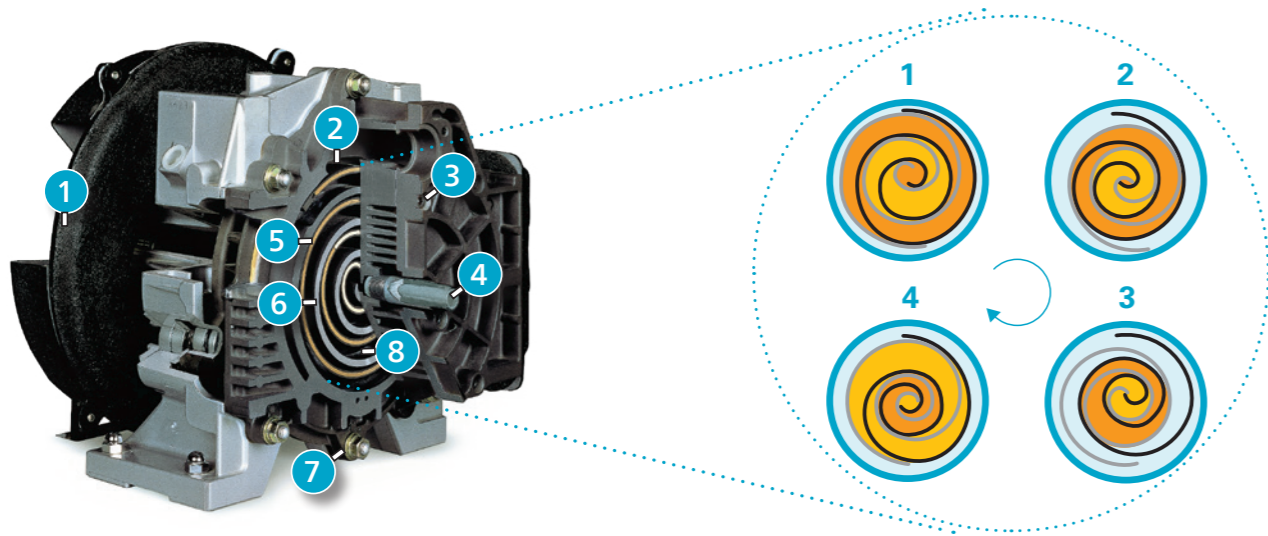

- 1 Cooling fan
- 2 Suction chamber
- 3 Suction opening
- 4 Delivery opening
- 5 Fixed scroll
- 6 Orbiting scroll
- 7 Fail-safe temperature sensor for unit protection
- 8 Compression chamber

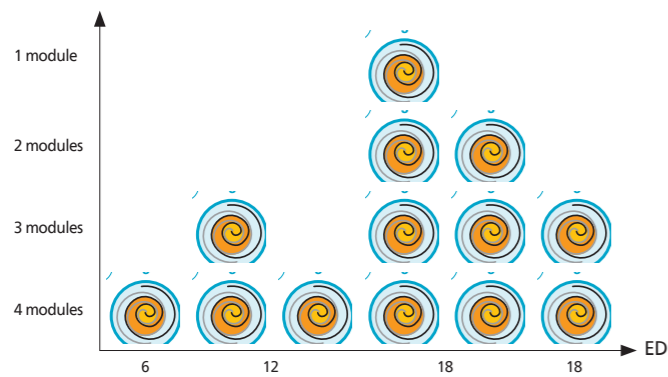

## Variable flow technology (VFT)

All SF+ 8-22 multi-scroll compressors are equipped with the unique VFT control system. The VFT system, included in the Elektronikon Touch controller, automatically starts and stops the scroll elements to exactly match the demands of your compressed air system. The Elektronikon Touch control algorithm ensures that the system pressure is kept within a very narrow pressure band.

# Complete integration, silent operation

Thanks to its low-noise operation, compact footprint and integration of air treatment equipment, the SF+ fits right on your work floor. This point-of-use installation helps minimize the size of your air distribution system, reduces pressure loss and the potential for leakage.



**Low noise**  
The slow speed of the scroll compression elements ensures that the SF+ is extremely quiet. Sound levels are as low as 52 dB(a), making the SF+ the perfect choice for your sensitive working environment.

Thanks to its compact footprint, the SF+ takes up very little space.

## Built-in quality air

Untreated compressed air contains moisture and aerosols which increase the risk of corrosion and compressed air system leaks. This can result in a damaged air system and contaminated end products. That's why the Full Feature version of the SF+ comes with a fully integrated refrigerated air dryer.



## Refrigerated dryer

- For applications that require ISO 8573-1 Class 4 air quality.
- Pressure dewpoint of 3°C/38°F (100% relative humidity at 20°C/68°F).
- On average 50% energy savings.
- Heat exchanger cross-flow technology with low pressure drop.
- Zero waste of compressed air thanks to no-loss condensate drain.
- Environmentally-friendly characteristics; zero ozone depletion.
- Global warming potential has been lowered significantly by an average of 50% by reducing the amount of refrigerant in the new dryer.

### ISO 8573-1

Quality classes	Particle size microns	Maximum pressure dewpoint		Maximum oil content (droplets, aerosols, and vapor ppm)	
		°C	°F	w/w	mg/m <sup>3</sup>
0	as specified	as specified		as specified	
1	0.1	-70	-94	0.008	0.01
2	1	-40	-40	0.08	0.1
3	5	-20	-4	0.8	1
4	15	3	38	4	5
5	40	7	45	21	25
6	–	10	50	–	–

\* The table values reflect the maximum limits according to the ISO quality air standard (ISO 8573-1:2010).  
\*\* Water pressure dewpoint based on 100% RH at 20°C/68°F.

# ISO 8573-1 Class 0

## The industry standard

Oil-free air is used in all kinds of industries where air quality is paramount for the end product and production process. These applications include food and beverage, pharmaceutical, chemical and petrochemical, semiconductor and electronics, the medical sector, automotive spray painting, textiles, and many more. In these critical environments, contamination by even the smallest quantities of oil can result in costly production downtime and product spoilage.

### First in oil-free air technology

Over the past sixty years, Atlas Copco has pioneered the development of oil-free air technology, resulting in a range of compressors and blowers that provide 100% pure, clean air. Through continuous research and development, Atlas Copco achieved a new milestone, setting the standard for air purity as the first manufacturer to be awarded Class 0 certification.

### Can oil-injected compressors with oil removal filters deliver oil-free air?

Often referred to as “technically oil-free air”, this system relies on air cooling devices and several stages of oil removal with multiple components. A failure of any of these components or inadequate maintenance can result in oil contamination. Therefore, with oil-injected compressors there will always be a risk of contamination and the possibility of severe consequences for your business.



### Eliminating any risk

As the industry leader committed to meeting the needs of the most demanding customers, Atlas Copco requested the renowned TÜV institute to type-test its range of oil-free compressors and blowers. Using the most rigorous testing methodologies available, all possible oil forms were measured across a range of temperatures and pressures. The TÜV found no traces of oil at all in the output air stream.

CLASS	Concentration total oil (aerosol, liquid, vapor) mg/m <sup>3</sup>
0	As specified by the equipment user or supplier and more stringent than class 1
1	< 0.01
2	< 0.1
3	< 1
4	< 5

Current ISO 8573-1 (2010) classes (the five main classes and the associated maximum concentration in total oil content).

### The most stringent air quality testing available

Most manufacturers prefer “partial flow” testing, which targets only the center of the air flow. The Atlas Copco SF+ range of oil-free scroll compressors was tested using the more stringent “full flow” method. This examines the entire air flow to measure aerosols, vapors, and wall flow. Even with such rigorous testing, no traces of oil were found in the output air stream.

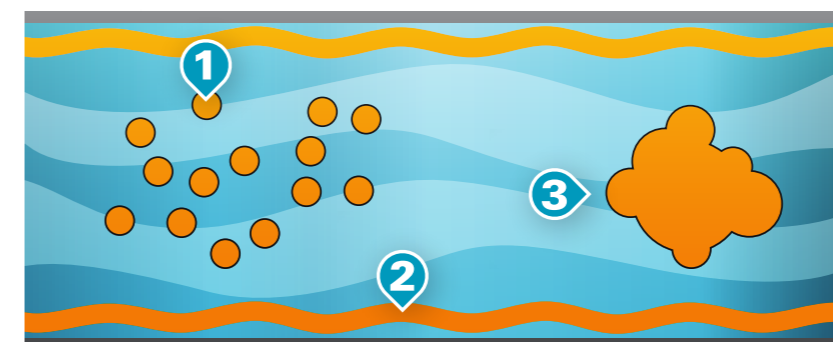

- 1 Aerosols  
Minute droplets of oil suspended in the air stream
- 2 Wall flow  
Oil in liquid form, which creeps along the pipe wall
- 3 Vapors or oil mist  
Vaporized oil in a cloud form

# A step ahead in monitoring and controls

## An advanced controller

The next-generation Elektronikon operating system offers a wide variety of control and monitoring features that allow you to increase your compressor's efficiency and reliability. To lower energy consumption, the Elektronikon controls the main drive motor and regulates system pressure within a predefined and narrow pressure band.



## Elektronikon Touch

- Ease of use: 4.3-inch high-definition color display with clear pictograms and service indicator.
- Reliable: user-friendly, multilingual user interface and durable keyboard.
- Flexible: four different week schedules for 10 consecutive weeks.
- Internet-based compressor visualization with a simple Ethernet connection.
- Remote control and connectivity functions.



## SMARTLINK remote connectivity

- Real-time monitoring of your compressor's operational parameters on your computer or mobile device.
- Performance data and insights identify opportunities for optimization.
- Service timeline.
- Maintenance and service alerts.
- Online resource center with manuals, documentation and technical information.

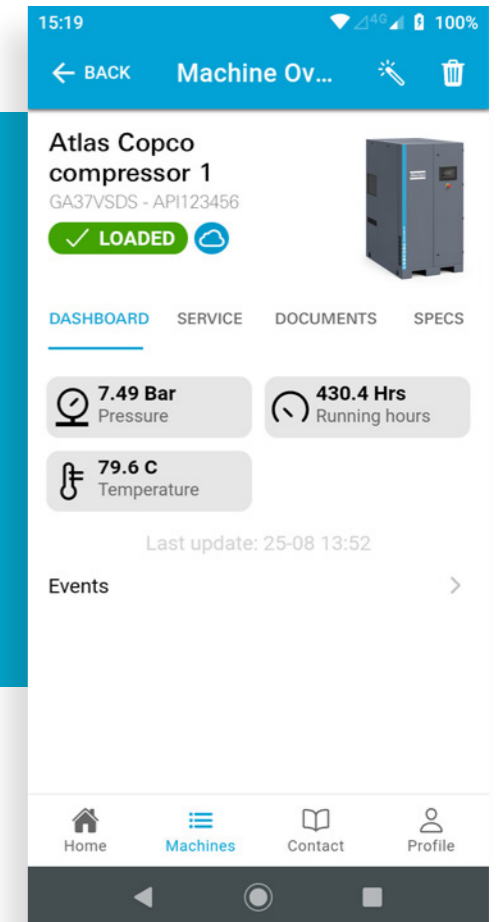

## Multiple compressor control

Manage up to 6 compressors in one air network with the EQ central controller (integrated in your compressor or as a standalone unit):

- **Reduced pressure band:** Create a narrow, predefined pressure band to save energy.
- **Optimal system performance:** Program all compressors to have equal running hours to reduce service intervals.
- **Improve reliability and efficiency:** With actionable performance reports, service warnings, and energy efficiency data.
- **Multiple compressor control:** Manage up to 6 compressors in one air network.

# Optimize your system

Some applications may need or may benefit from additional features and more refined control/air treatment systems. To meet these needs, Atlas Copco has developed optional parts and easily integrated compatible equipment.

## SF+ 1-6

- CD adsorption dryer (only for FF TM variants)
- Phase Sequence Relay
- Prefiltration kit
- EQ4i central compressor control
- EQ6i central compressor control
- Integrated 30l air receiver + timer drain
- 270l air receiver
- 500l air receiver
- Timer drain on air receiver (only for tank-mounted variants)
- WSD water separator drain (only for Pack FM variants)

## SF+ 8-22

	SF+ 8-11	SF+ 15-22
Extra module upgrade SF+ 8-15	•	-
EQ4i central compressor control	•	•
EQ6i central compressor control	•	•
Test report	•	•
Electronic water drain (Pack units only)	•	•
Main switch	•	•

- Optional
- Not available



## AIRnet compressed air piping systems

The right piping system makes all the difference. AIRnet ensures that your compressed air reaches your point of use in optimal conditions:

- Complete system with pipes in different materials, fittings, and point-of-use accessories.
- Smooth air flow and stable pressure.
- High air quality thanks to non-corrosive materials.
- Turnkey, dynamic design with flexible, interchangeable, and reusable fittings.
- Fast installation and no maintenance needed.

Contact us today for more information about AIRnet. Our experts can help you size, plan and install your AIRnet system to ensure it supports your production with maximum energy efficiency and minimal total cost of ownership.

## Technical specifications SF+ 1-6

Compressor type	Pressure variant	Max. working pressure Pack		Capacity FAD*			Installed motor power		Noise level**	Weight Pack	
		bar(e)	psig	l/s	m <sup>3</sup> /min	cfm	kW	hp		kg	lbs
SF 1*	8	8	116	2.9	0.17	6.1	1.5	2	52	120	265
	10	10	145	1.9	0.11	4.0	1.5	2	52	120	265
SF 2*	8	8	116	4.2	0.25	8.9	2.2	3	56	125	276
	10	10	145	3.4	0.20	7.2	2.2	3	56	125	276
SF 4*	8	8	116	6.7	0.40	14.2	3.7	5	58	133	293
	10	10	145	5.9	0.35	12.5	3.7	5	58	133	293
SF 6*	8	8	116	9.8	0.59	20.8	5.5	7.5	59	157	346
	10	10	145	7.6	0.46	16.1	5.5	7.5	59	157	346

\*Unit performance measured according to ISO 1217, Annex C, Latest Edition.

\*\*Mean noise level measured at a distance of 1 m according to ISO 2151, tolerance 3 dB(a). Weights of the pack & floor-mounted units are shown in the chart.

## Technical specifications SF+ 8-22

Compressor type	Pressure variant	Max. working pressure Pack		Capacity FAD*			Installed motor power		Noise level**	Weight Pack		Weight Full Feature	
		bar(e)	psig	l/s	m <sup>3</sup> /hr	cfm	kW	hp		kg	lbs	kg	lbs
SF 8*	8	8	116	13.4	0.80	28.4	8	10	63	387	853	402	886
	10	10	145	11.3	0.68	23.9	8	10	63	387	853	402	886
SF 11*	8	8	116	21.1	1.27	44.7	11	15	63	442	974	457	1007
	10	10	145	15.0	0.90	31.8	11	15	63	442	974	457	1007
SF 15*	8	8	116	27.2	1.63	57.6	15	20	63	583	1285	603	1329
	10	10	145	22.6	1.36	47.8	15	20	63	583	1285	603	1329
SF 17*	8	8	116	31.5	1.89	66.7	17	22	64	645	1422	665	1466
	10	10	145	23.5	1.41	49.7	17	22	64	645	1422	665	1466
SF 22*	8	8	116	41.1	2.47	87.0	22	30	65	745	1642	765	1686
	10	10	145	29.7	1.78	62.9	22	30	65	745	1642	765	1686

\*Unit performance measured according to ISO 1217, Annex C, Latest Edition.

\*\*Mean noise level measured at a distance of 1 m according to ISO 2151, tolerance 3 dB(a). Weights of the pack & floor-mounted units are shown in the chart.

## Dimensions SF+ 1-6

	Pack/Full Feature					
	L (mm)	W (mm)	H (mm)	L (in)	W (in)	H (in)
Pack & floor-mounted	760	670	840	29.9	26.3	33.1
Full Feature & floor-mounted	1025	670	840	40.3	26.3	33.1
Pack & 270l receiver	1275	670	1450	50.2	26.3	57.1
Full Feature & 270l receiver	1275	670	1450	50.2	26.3	57.1



## Dimensions SF+ 8-22

	Pack/Full Feature					
	L (mm)	W (mm)	H (mm)	L (in)	W (in)	H (in)
SF+ 8-11 LC* Pack & Full Feature	1630	750	1230	64.2	29.5	48.4
SF+ 8-11 HC* Pack & Full Feature	1630	750	1840	64.2	29.5	72.4
SF+ 15-22 Pack & Full Feature	1630	750	1840	64.2	29.5	72.4

\*LC= low canopy; HC= high canopy.







ISO 9001 · ISO 14001  
OHSAS 18001

**Atlas Copco**

[atlascopco.com](https://atlascopco.com)

