

The Atlas Copco logo is located in the top right corner of the image. It consists of the company name "Atlas Copco" in a white, italicized serif font, centered between two horizontal white bars. The background of the entire image is a low-angle photograph of industrial machinery, featuring large vertical pipes, ladders, and walkways against a clear blue sky. A teal-colored graphic overlay with technical drawings is positioned in the bottom left corner.

Atlas Copco

ECOTS™ and ECOTS-M™

Atlas Copco Gas and Process offers
the most trusted, proven and reliable
turboexpanders in the industry

HANDLE THE PRESSURE

Proven Expander Experience



45 Years of
Expander
Expertise



Installed
in over
50
Countries



Over
1000
Installations
Worldwide

ECOTS™



Over **150** units sold

Magnetic Bearing

Over **7.5M** operating hours

29 years experience

Over **140** units sold

Industries we serve



Gas Processing



Petrochemical



LNG & Energy Recovery

The best of both worlds for process refrigeration and compression

In 2011, Atlas Copco Gas and Process introduced the ECOTS™ family of pre-engineered Expander-Compressors into the Natural Gas Processing marketplace. The mission: reduce equipment deliveries by 30-40% without compromising on performance, reliability, and operability. The result: mission accomplished! Over 150 ECOTS™ expander units have been sold since that initial introduction, representing over 25 Bcf/d of gas processing capacity.

As the industry leader in turboexpander technology, we have engineered these products to be adaptable to any process need with the option of customizable aerodynamic components. Our customers benefit from the cost and delivery advantages of an off the shelf product, that is also tuned to their specific process needs.

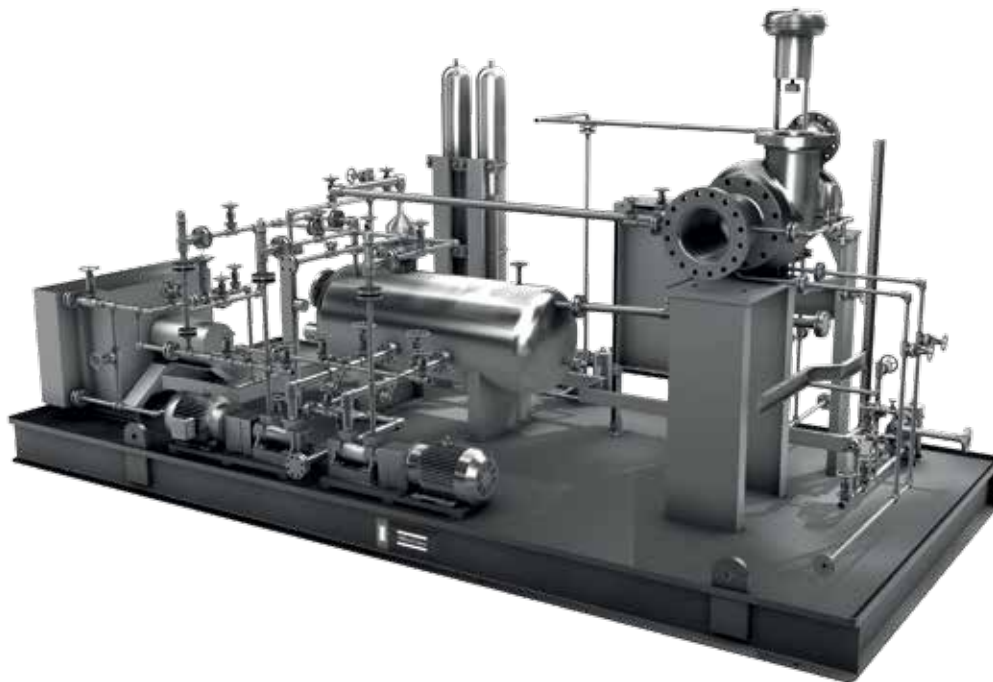
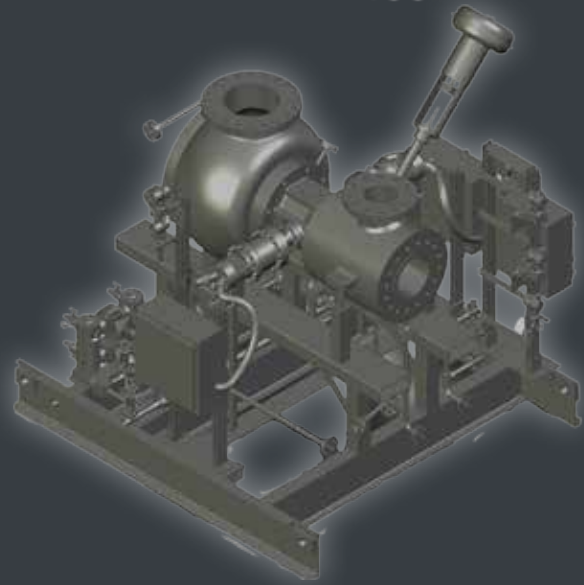

ECOTS™ and ECOTS-M™: The right match for shale gas processing applications

Atlas Copco Gas and Process ECOTS™ expanders are built to accommodate all gas processing plant applications. The units are skid-mounted with their auxiliary systems to simplify transport and help reduce installation cost. The ECOTS™ product features a lube-oil bearing system,

while the more compact ECOTS-M™ features an oil-free Active Magnetic Bearing (AMB) system. There are hundreds of ECOTS™ units in operation worldwide, proving the durability and reliability of these Atlas Copco Gas and Process machines.

High efficiency and broad operating range

The ECOTS™ family of machines are aerodynamically optimized for peak process performance. Expander and compressor wheels have been designed using state-of-the-art software tools and are the most efficient in the industry.

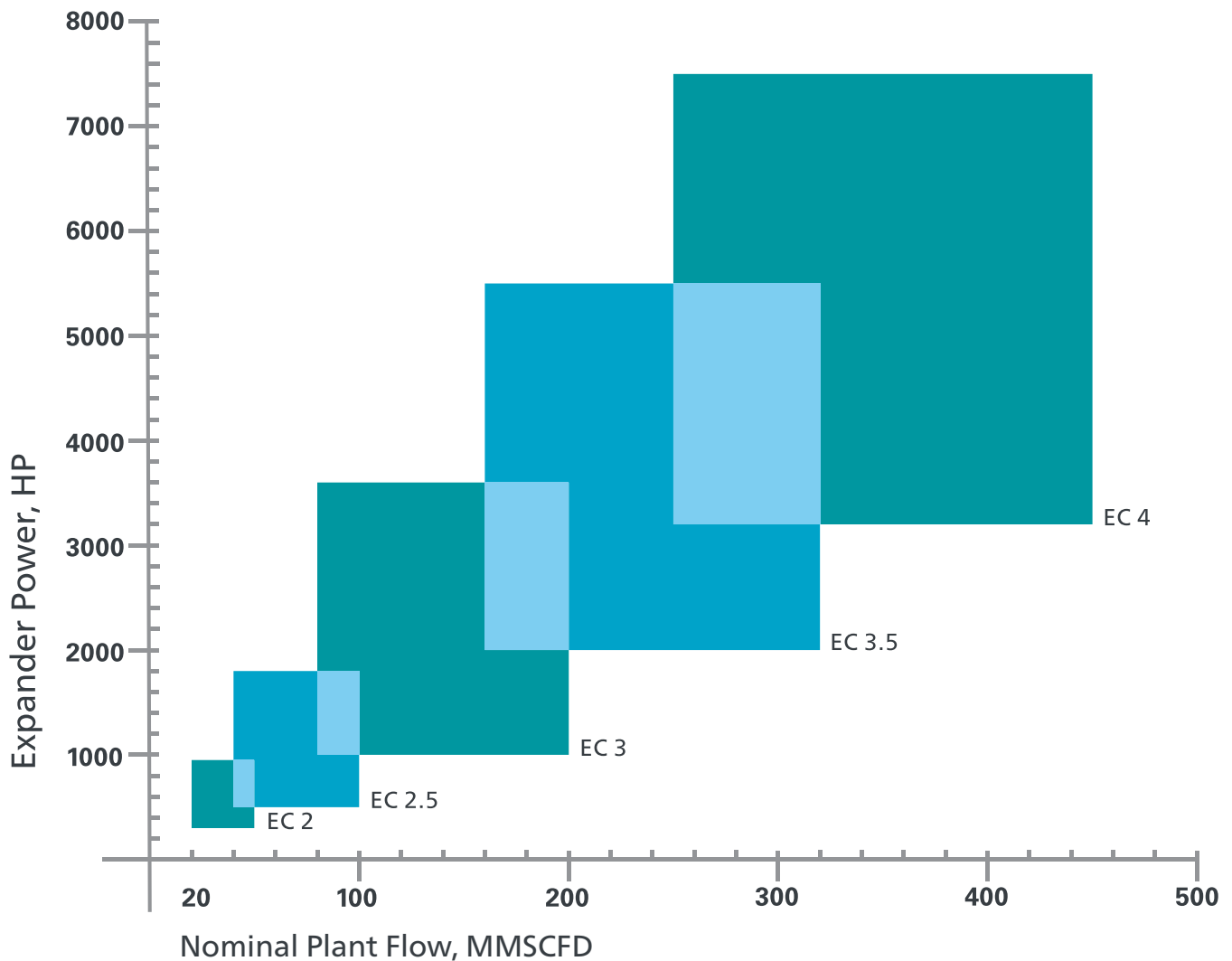

- 5 frame sizes to cover the full range of shale gas processing plants (20 to 450 MMSCFD)
- Expander isentropic efficiencies of 84 to 87%
- Compressor polytropic efficiencies of 77 to 82%
- Mechanical efficiencies of 98 to 99.5%
- Expander flow range of 0 to 125% of design
- Compressor flow range of 75 to 125% of design (0 to 125% of design with surge control)

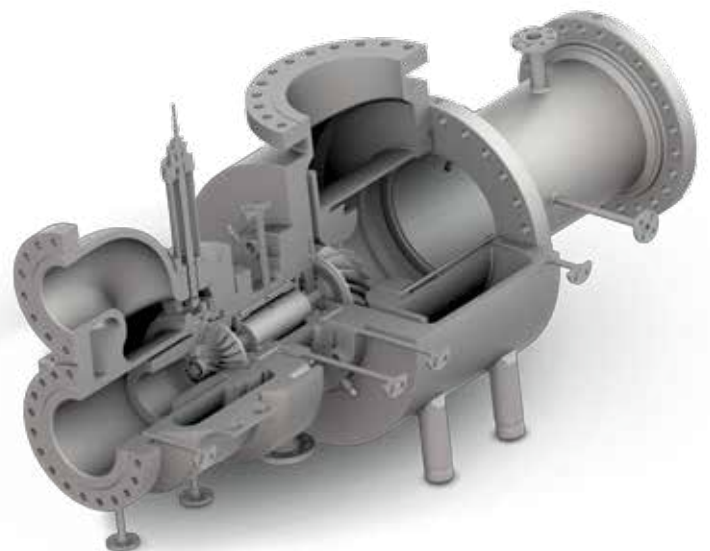



The technical edge

ECOTS-M™: The oil free magnetic bearing turboexpander option.

When your process demands an innovative, oil-free turboexpander solution, Atlas Copco Gas and Process has you covered with our ECOTS-M™. An evolution of our standard ECOTS™ product, the ECOTS-M™ turboexpander is more compact and features Active Magnetic Bearing (AMB) technology.

- Available in all ECOTS™ frame sizes
- Ideal for cold weather applications that can affect oil viscosity
- Lower OPEX costs due to the elimination of the lube-oil system
- Proven reliability: Uses AMB technology proven by over 140 units sold with a combined service time of over 7.5 million hours
- Remotely mounted indoor control cabinet improves availability over skid-mounted control cabinet by eliminating hazardous area purge and cooling systems
- Dual process seals included (per NFPA 70) for safety

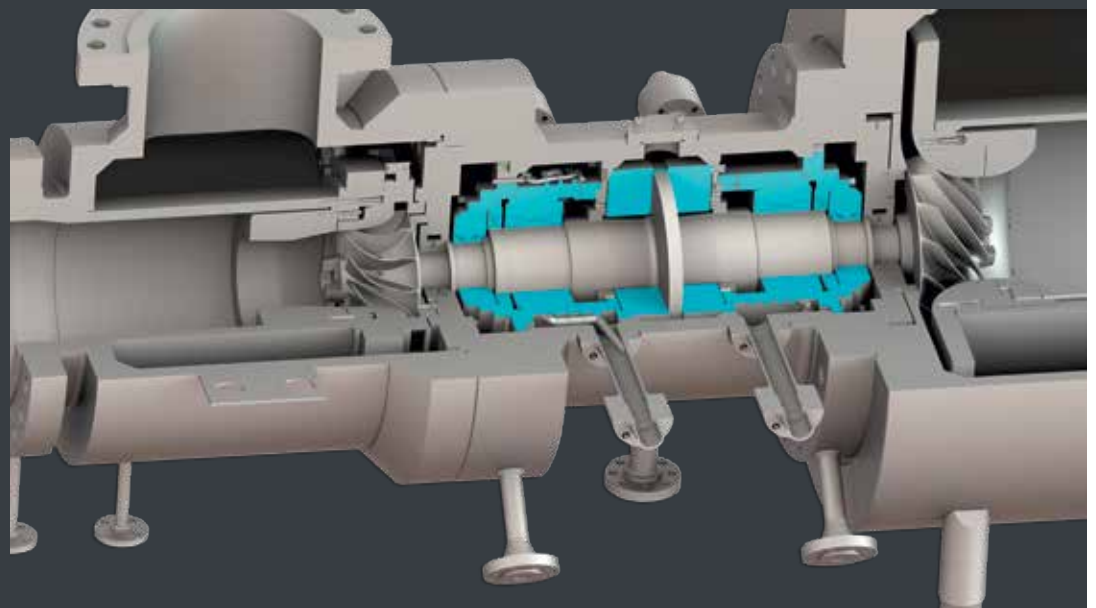

High Availability

ECOTS™ and ECOTS-M™ both use proven Atlas Copco design elements (wheels, bearings and rotor, IGV system, shaft seals, and casings) installed on a more standardized package. With ECOTS™, you don't have to compromise on performance, operability, or reliability; with availability averaging over 99% for either oil or magnetic bearings. Features include:

- Redundant lube oil pumps (ECOTS™)
- Duplex lube oil and seal gas filters (ECOTS™)
- Active Magnetic Bearing (AMB) technology (ECOTS-M™)
- Machine and process protection
- Automated lube oil and seal gas monitoring, operation and protection (ECOTS™)
- Pressurized lube oil reservoir that recovers 100% of seal gas – 0 emissions from gas venting (ECOTS™)
- Labyrinth process gas seals – the most robust seal configuration in the market

Shorter Delivery Times

A benefit of the ECOTS™ family of expanders is shortened delivery times. We consistently see a 30% to 40% improvement in delivery compared to custom-engineered units.

- Upfront engineering phase is already completed and selected long-lead components are in stock
- Standardized package P&ID, GA
- Common I&C and auxiliary component subvendors used for all frame-size ECOTS™ units
- Standard expander and compressor casings and customer interfaces
- Simplified package manufacturing and Atlas Copco Gas and Process QA/QC approved packaging vendors eliminate potential production bottlenecks



Your total turbomachinery supplier

Atlas Copco Gas and Process is your trusted turbomachinery supplier in the gas processing market. Over 80 years in the rotating equipment industry has enabled us to engineer extremely robust, reliable and efficient equipment that results in lower commissioning and operating costs. We offer every expander and compressor needed within a standard gas processing facility.

By partnering with Atlas Copco, you can take advantage of single-vendor convenience with respect to T&Cs, logistics and enhanced project execution support. This, combined with multiple production facilities throughout the world, ensures we have the resources to manufacture your orders in a timely manner.



